

IMPORTANT SAFETY INSTRUCTIONS

Putting sewing systems into operation is prohibited until it has been ascertained that the sewing systems in which these sewing machines will be built into, have conformed with the safety regulations in your country. Technical service for those sewing systems is also prohibited.

1. Observe the basic safety measures, including, but not limited to the following ones, whenever you use the machine.
2. Read all the instructions, including, but not limited to this Instruction Manual before you use the machine. In addition, keep this Instruction Manual so that you may read it at anytime when necessary.
3. Use the machine after it has been ascertained that it conforms with safety rules/standards valid in your country.
4. All safety devices must be in position when the machine is ready for work or in operation. The operation without the specified safety devices is not allowed.
5. This machine shall be operated by appropriately-trained operators.
6. For your personal protection, we recommend that you wear safety glasses.
7. For the following, turn off the power switch or disconnect the power plug of the machine from the receptacle.
 - 7-1 For threading needle(s), loopier, spreader etc. and replacing bobbin.
 - 7-2 For replacing part(s) of needle, presser foot, throat plate, loopier, spreader, feed dog, needle guard, folder, cloth guide etc.
 - 7-3 For repair work.
 - 7-4 When leaving the working place or when the working place is unattended.
 - 7-5 When using clutch motors without applying brake, it has to be waited until the motor stopped totally.
8. If you should allow oil, grease, etc. used with the machine and devices to come in contact with your eyes or skin or swallow any of such liquid by mistake, immediately wash the contacted areas and consult a medical doctor.
9. Tampering with the live parts and devices, regardless of whether the machine is powered, is prohibited.
10. Repair, remodeling and adjustment works must only be done by appropriately trained technicians or specially skilled personnel. Only spare parts designated by JUKI can be used for repairs.
11. General maintenance and inspection works have to be done by appropriately trained personnel.
12. Repair and maintenance works of electrical components shall be conducted by qualified electric technicians or under the audit and guidance of especially skilled personnel. Whenever you find a failure of any of electrical components, immediately stop the machine.
13. Before making repair and maintenance works on the machine equipped with pneumatic parts such as an air cylinder, the air compressor has to be detached from the machine and the compressed air supply has to be cut off. Existing residual air pressure after disconnecting the air compressor from the machine has to be expelled. Exceptions to this are only adjustments and performance checks done by appropriately trained technicians or especially skilled personnel.
14. Periodically clean the machine throughout the period of use.
15. Grounding the machine is always necessary for the normal operation of the machine. The machine has to be operated in an environment that is free from strong noise sources such as high-frequency welder.
16. An appropriate power plug has to be attached to the machine by electric technicians. Power plug has to be connected to a grounded receptacle.
17. The machine is only allowed to be used for the purpose intended. Other used are not allowed.
18. Remodel or modify the machine in accordance with the safety rules/standards while taking all the effective safety measures. Our company no responsibility for damage caused by remodeling or modification of the machine.
19. Warning hints are marked with the two shown symbols.



Danger of injury to operator or service staff



Items requiring special attention

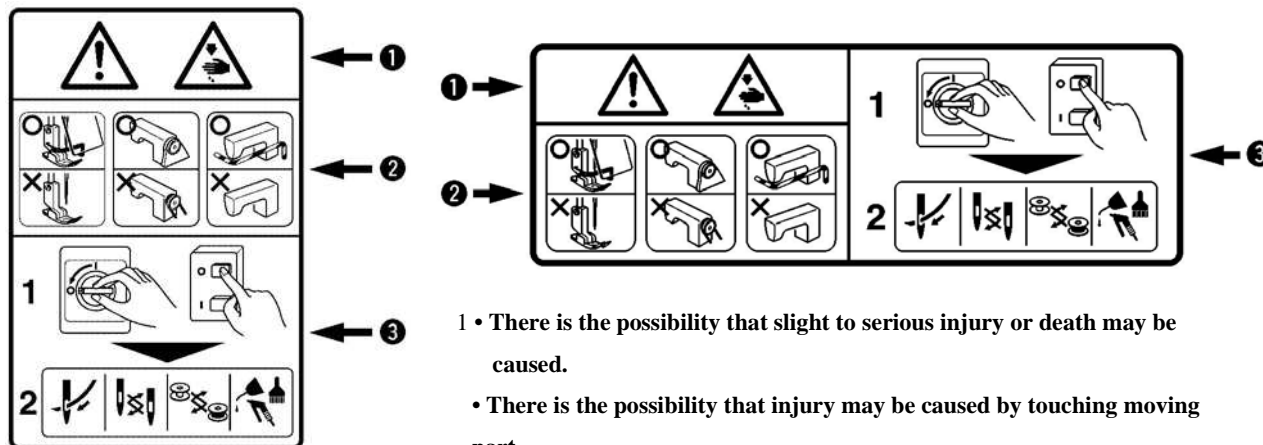

- 1 • There is the possibility that slight to serious injury or death may be caused.
 - There is the possibility that injury may be caused by touching moving part.
- 2 • To perform sewing work with safety guard.
 - To perform sewing work with safety cover.
 - To perform sewing work with safety protection device.
- 3 • Turn OFF the power and perform “threading”, “replacement of bobbin or needle”, “cleaning”, “adjustment” and “lubrication”.

FOR SAFE OPERATION







1. To avoid electrical shock hazards, neither open the cover of the electrical box for the motor nor touch the components mounted inside the electrical box.
2. After changing the pattern, make sure the needle entry point. If the pattern is protruded from the work clamp feet, the needle will interfere with the work clamp feet during sewing, and it is dangerous due to the needle breakage or the like.
3. Do not turn OFF the power in a state that the needle is lowered. Wiper may break the needle.



1. When nothing is displayed in the operation panel even when the power switch is turned ON, turn OFF the power switch and check the voltage and the type of the power source.
2. So as to prevent possible accidents caused by abrupt start of the sewing machine, depress the start switch after ascertaining that there is no interfering thing under the needle when winding the bobbin thread.
3. When turning OFF the power switch, turning ON the ready switch or turning ON the work clamp foot switch, the work clamp feet automatically come down. So, never place your fingers under the work clamp feet to prevent possible accidents caused by abrupt start of the sewing machine. During operation, be careful not to allow your fingers to come close to the work clamp feet.
4. So as to prevent possible accidents caused by the touch of the fingers with the needle, install a finger guard suitable for each work clamp foot when replacing the work clamp foot.

CONTENTS

I . EXPLANATION OF 1900D, COMPUTER-CONTROLLED HIGH-SPEED BAR TACKING MACHINE

[1] SPECIFICATIONS.....	1
[2] CONFIGURATION.....	2
1. Names of main unit.....	2
[3] INSTALLATION.....	3
1. Installing the electrical box.....	3
2. Attaching the connecting rod.....	3
3. Installing the head support rod.....	3
4. Installing and connecting the power switch.....	4
5. Installation of the sewing machine head.....	4
6. Installing the drain receiver and the head support rubber.....	5
7. Safety switch.....	5
8. Tilting the sewing machine head.....	6
9. Installing the operation panel.....	6
10. Connecting the cord.....	6
11. Installing the motor cover.....	7
12. Installing the eye protection cover.....	7
13. Installing the thread stand.....	8
[4] OPERATION OF THE SEWING MACHINE.....	8
1. Lubrication.....	8
2. Attaching the needle.....	9
3. Threading the machine head.....	9
4. Installing and removing the bobbin case.....	10
5. Installing the bobbin.....	10
6. Adjusting the thread tension.....	11
7. Adjusting the thread take-up spring.....	11
[5] OPERATION OF THE SEWING MACHINE	12
1. Names and explanation of switches on the operation panel.....	12
2. Item data setting.....	13
3. Checking the contour of a sewing pattern.....	16
4. Sewing.....	17
5. Change to the other sewing pattern.....	17
6. Winding a bobbin.....	18
7. Independent thread-trimming device.....	18
8. Thread-catching device.....	18
9. Bottom thread counter.....	20
10. Pause.....	20
11. Set P pattern & C pattern.....	21
11-1. Use pattern key (    ) for sewing.....	21
11-2. Sewing with combination functions.....	23

12. Debugging mode.....	26
12-1. CP-1 Input signal test.....	28
12-2. CP-2 Check X/Y motor/origin sensor.....	29
12-3. CP-3 Continuous running.....	30
12-4. CP-4 Test Main motor speed.....	31
12-5. CP-5 Adjustment on thread-trimming.....	32
12-6. CP-6 Test presser origin sensor.....	34
12-7. CP-7 Test thread-catching motor/ origin sensor.....	35
13. Parameter setting.....	36
13-1. Specific operations on setting parameters.....	36
13-2. Example for setting parameters.....	36
13-3. Table for parameter setting.....	41
14. Setting of service parameter.....	44
14-1. Activation & modification of service parameter.....	44
14-2. Table of service parameters.....	44
14-3. Recovery to default setting.....	46
[6] MAINTENANCE.....	48
1. Adjusting the height of the needle bar.....	48
2. Adjusting the needle-to-shuttle relation.....	48
3. Adjusting the lift of the work clamp foot.....	50
4. The moving knife and counter knife.....	50
5. Needle thread clamp device.....	51
6. Adjustment of the wiper.....	51
7. Draining waste oil.....	52
8. Amount of oil supplied to the hook.....	52
9. Replenishing the designated places with grease.....	53
[7] Table of the standard patterns and the standard patterns.....	54
1. List of Standard Figure.....	54
2. Table of the standard patterns.....	58
[8] Table of the optional parts.....	60
II. EXPLANATION OF THE 1903D, COMPUTER-CONTROLLED HIGH-SPEED LOCKSTITCH BUTTON SEWING MACHINE.....	62
[1] Specifications.....	62
[2] Installation of the sewing machine and preparation of the operation.....	62
[3] Needle and thread.....	62
[4] Every kind of pattern stitches.....	63
1. Table of the standard patterns.....	63
2. The choice of the pattern and the width.....	64
[5] Position of the button clamp jaw lever.....	65
[6] Adjusting the feed plate.....	66
[7] Adjusting the button clamp jaw lever.....	66
[8] Adjusting the lifting amount of the button clamp.....	67
[9] Adjustment of the pressure of the work clamp unit.....	67
[10] Adjustment of the wiper spring.....	68

[11] Each model of 1903D sewing scope.....	68
III.List of Error Information.....	69
IV.Troubles and corrective measures (sewing conditions).....	73
V.The system diagram of the electricity controls.....	76
VI.DRAWING OF THE TABLE.....	77

I . EXPLANATION OF 1900DSS, COMPUTER-CONTROLLED HIGH SPEED BAR TACKING MACHINE

[1] SPECIFICATIONS

- | | |
|------------------------------------|--|
| 1. Sewing area: | X (lateral) direction 40mm,
Y (longitudinal) direction 30mm |
| 2. Max. Sewing speed: | 3000rpm
(when sewing pitches are less than 5mm in X-direction and 3.5mm in Y-direction) |
| 3. Stitch length: | 0.1-10mm (adjustable in 0.1mm step) |
| 4. Feed motion of work clamp foot: | Intermittent feed (2-shaft drive by stepping motor) |
| 5. Needle bar stroke: | 41.2mm |
| 6. Needle: | DP×5、 DP×17 |
| 7. Lift of work clamp foot: | 13mm (standard) Max.17mm |
| 8. Shuttle: | standard semi-rotary hook (oil wick lubrication) |
| 9. lubricating: | oil 10# (supplied by oiler) |
| 10. Date recording: | EPROM |
| 11. Enlarging/Reducing facility: | 20% to 200% (1% step) in X-direction and Y-direction respectively |
| 12. Enlarging/Reducing: | Patten enlargement/reduction can be done by increasing/decreasing the stitch length |
| 13. Max. Sewing speed limitation: | 400 to 3200rpm (100rpm) |
| 14. Pattern selection: | Specifying pattern No. type (1 to 200) |
| 15. Bobbin thread counter: | UP/DOWN type (0-9999) |
| 16. Sewing machine motor: | 500W Servo motor |
| 17. Dimensions: | W: 1200mm L: 540mm H: 1100mm |
| 18. Weight: | Machine head 55Kg Control box 6Kg |
| 19. Power consumption: | 0.6KW |
| 20. Operating temperature range: | 5°C to 35°C |
| 21. Operating humidity range: | 35% to 85% (No dew condensation) |
| 22. Line voltage: | Rated voltage ±10% 50-60Hz |

[2] CONFIGURATION

1. Names of main unit

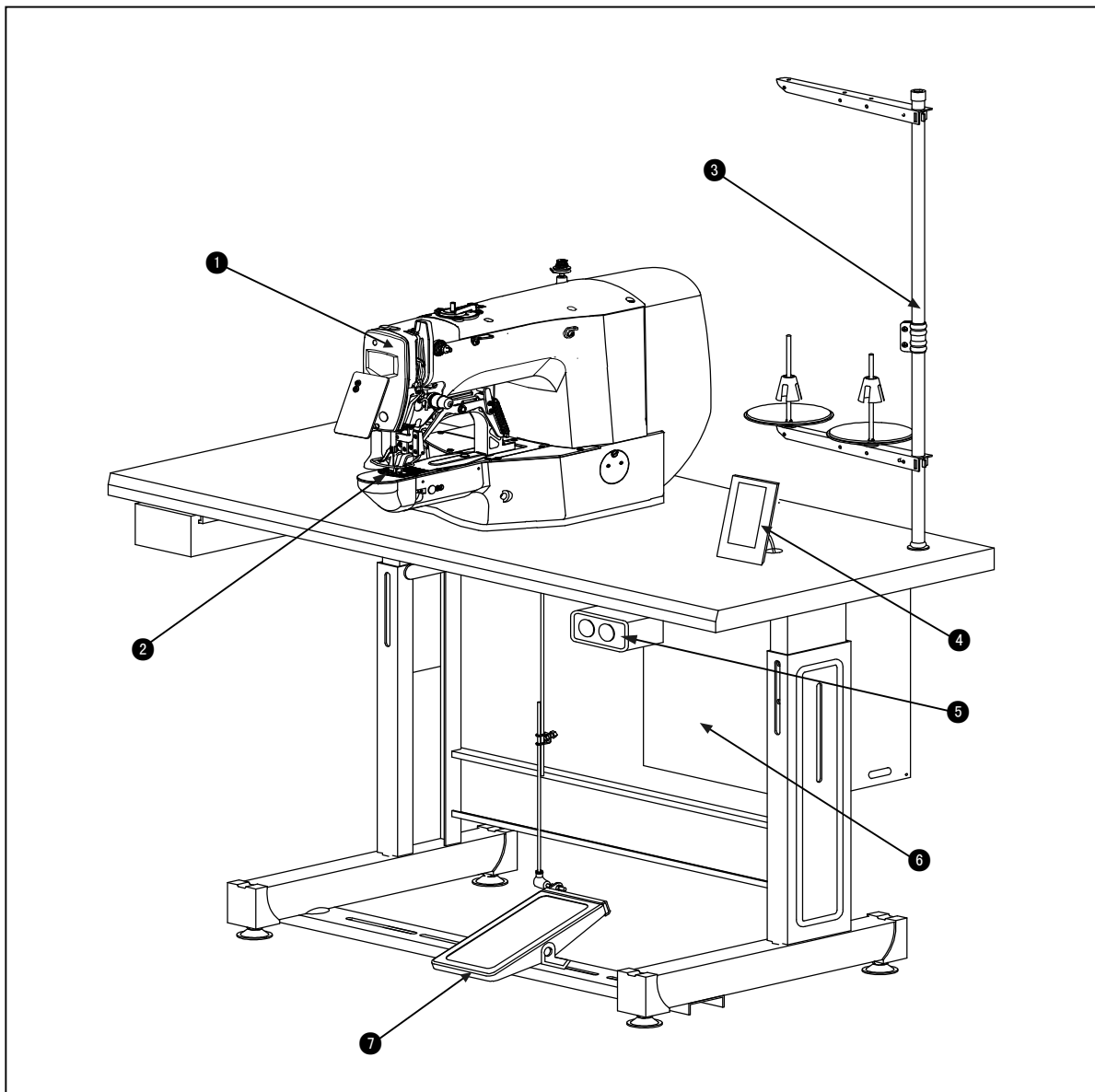

- (1). Machine head
- (2). Work clamp feet
- (3). Thread stand
- (4). Operation panel
- (5). Power switch
- (6). Control box
- (7). Pedal switch

[3] INSTALLATION

1. Installing the electrical box

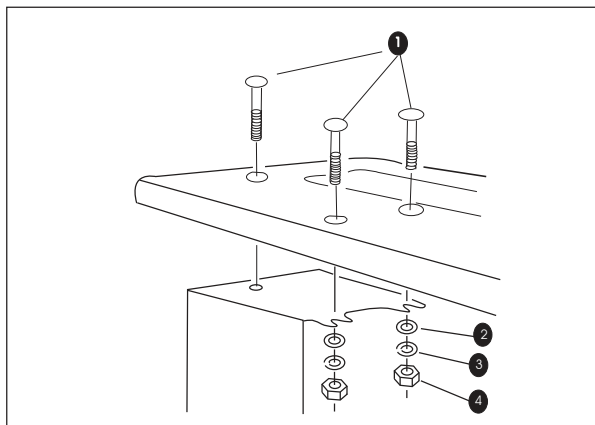

Install the electrical box on the underside of the table at the location illustrated using round-head bolt ①, plain washer ②, spring washer ③ and nut ④ supplied with the machine.

2. Attaching the connecting rod

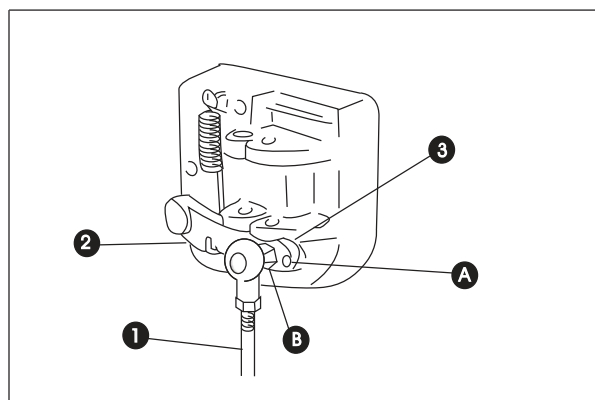

FIX connecting rod ① to installing hole B of pedal lever ② with nut ③. When connecting rod ① is installed in installing hole A, the depressing stroke go the pedal is increased.

3. Installing the head support rod

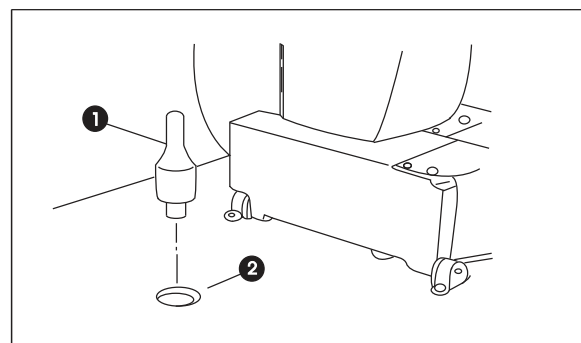

Drive head support rod ① in hole ② in the machine table.

4. Installing and connecting the power switch

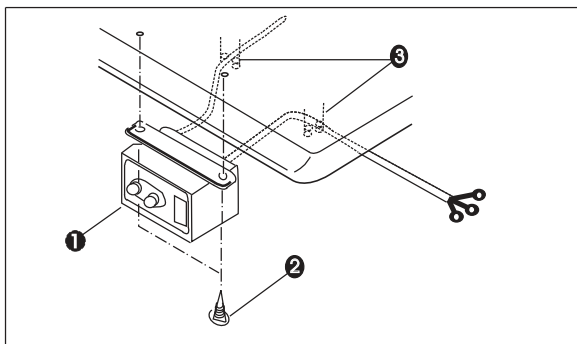

Fix power switch ① under the machine table with screws ②. Fix the cable with staples ③ supplied with the machine as accessories in accordance with the forms of use.

5. Installation of the swing machine head



WARNING : To prevent possible accidents caused by the full of the sewing machine, perform the work by two persons or more when the machine is

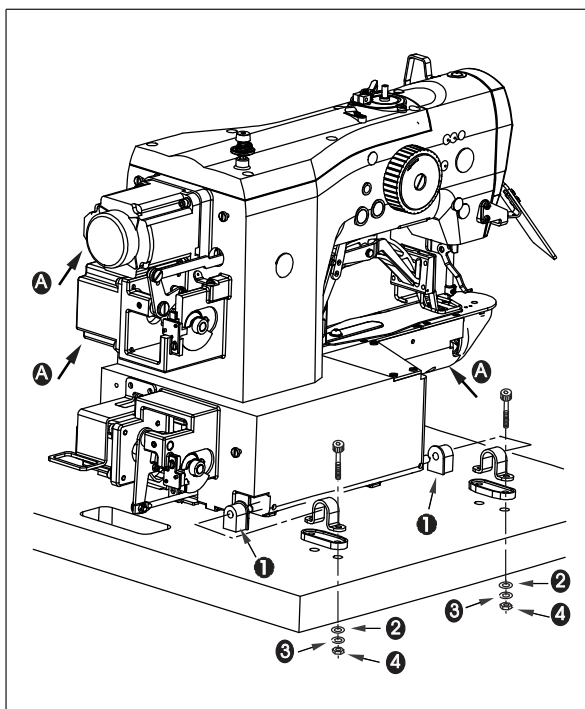

- (1). Fit hinge rubber ① to the hinge shaft, and fix the swing machine main unit.
- (2). The flat pad ②, elastic pad ③, nut icon ④ followed by a fixed, pay attention to the locking nut ④ force, if twisted too tightly, then the shock result is not satisfactory.

6. Installing the drain receiver and the head support rubber

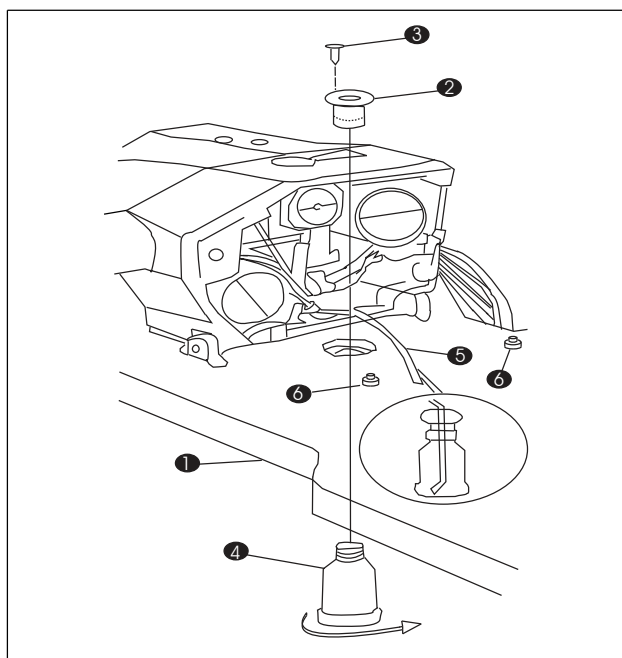

- (1). Fix drain receiver ② in the installing hole of table ① with four setscrews③. Screw in drain bin ④ to drain receiver②. Insert sewing machine drain pipe⑤ into drain bin ④ .
- (2).Insert head support rubber⑥ into table ①.

Insert drain pipe⑤ until it will go on further so that it does not come off drain bin ④ when tilting the machine head

7. Safety switch

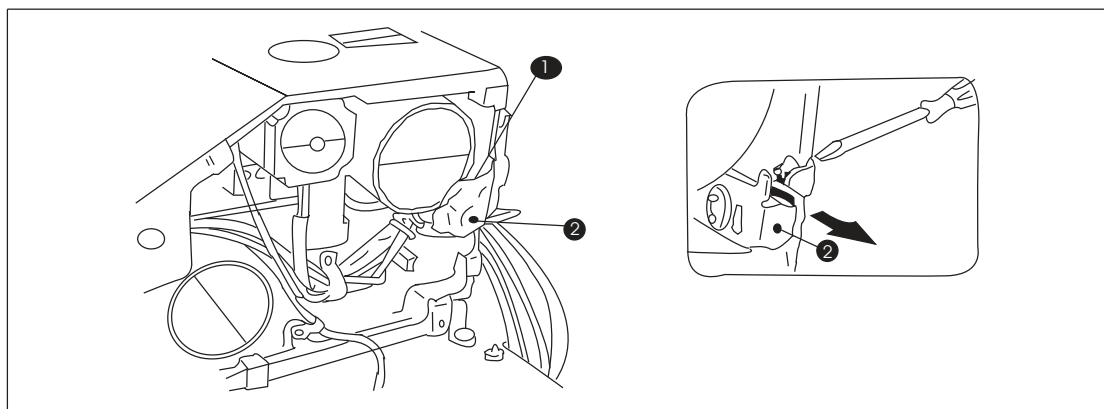

cut off the safety switches cable ties which be fixed under the machine, safety switches will be installed in the machine as shown here, with screw lock, overturning the head, checking the suitability of the safety switch mounting position, heads up is required, Table board to open the safety switch top picks, picks of safety switches and safety switches do not touch, otherwise the error E302

1.If you do not remove the safety switch, and installed in the correct position, machine will can't sewing;
2.Safety switches installed, if happen error E302, please adjust the security switch down, to ensure the safety switch picks with the table adequate contacts.

8. Tilting the sewing machine head

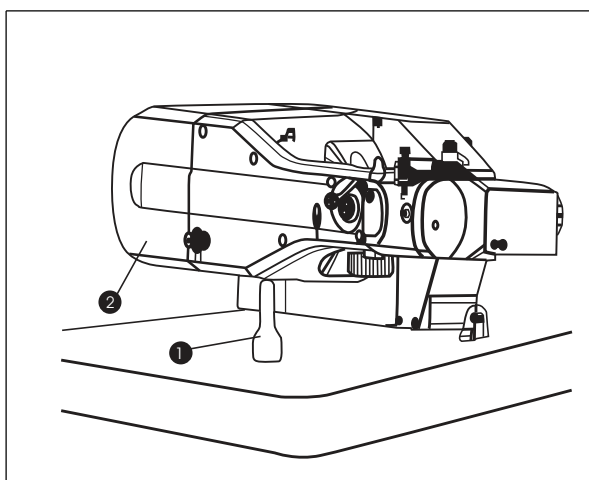

turn head① gently down , and leaning the head on the head supporting bar at ②.



1. Before tilting the sewing machine head, make sure that head support rod ① is attached to the machine table;
2. When raising the sewing machine head, do not raise it while holding motor cover ②. It will be the cause of breakage of motor cover②.
3. Be sure to tilt the sewing machine head on a flat place to prevent it from falling.

9. Installing the operation panel

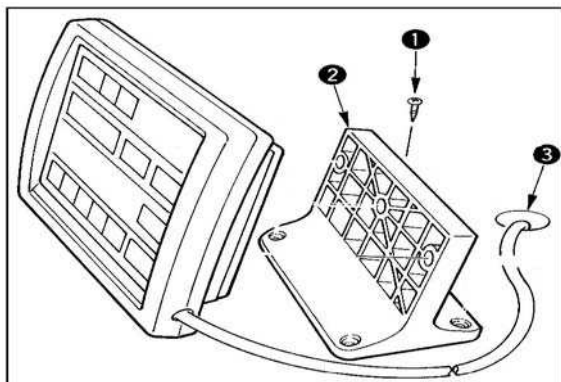

Use four wood screws① fix the operator panel ② on the table ③ in a comfortable operation position, then the operator panel② corresponding wire hole through the table③, and then dock with the other side.

10. Connecting the cord

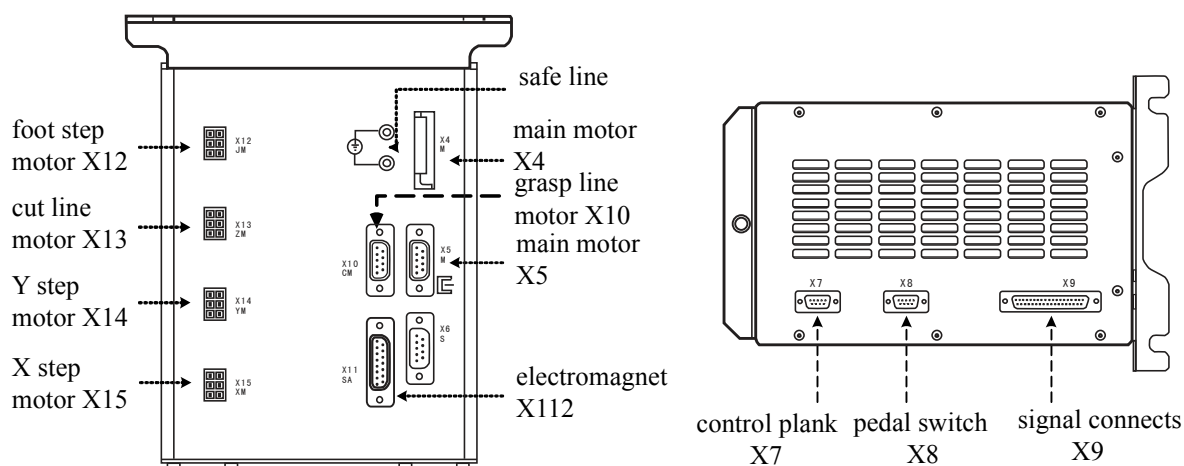

Please let the motor cable, the signal line of the machine head connect with the electronic control box according to online identity, make sure the connection is correct, there is no omission.

11. Installing the motor cover

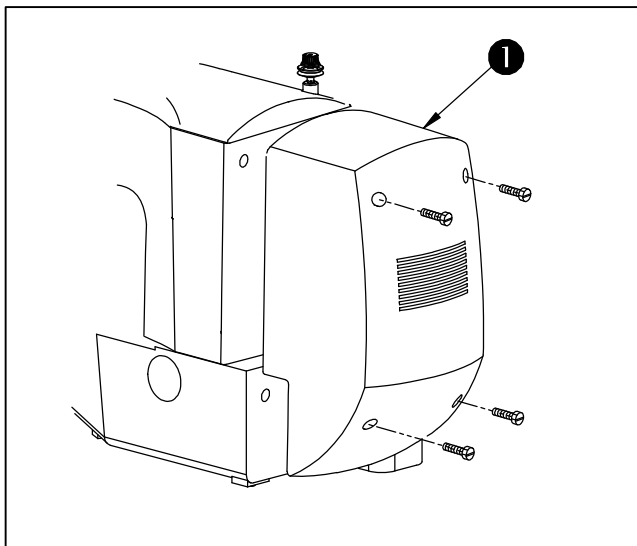

Install motor cover① on the machine main unit with screws supplied with the machine as accessories

12. Installing the eye protection cover



WARNING : Be sure to attach this cover to protect the eyes from the disperse of needle breakage.

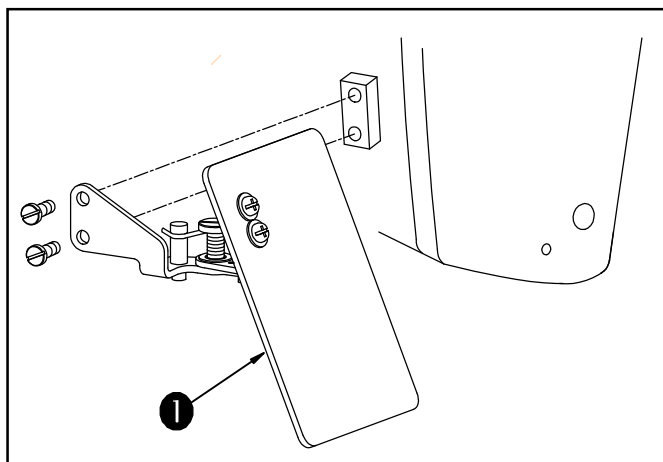

The eye shield in the accessories box should be installed in the head on the left.

13. Managing the cord

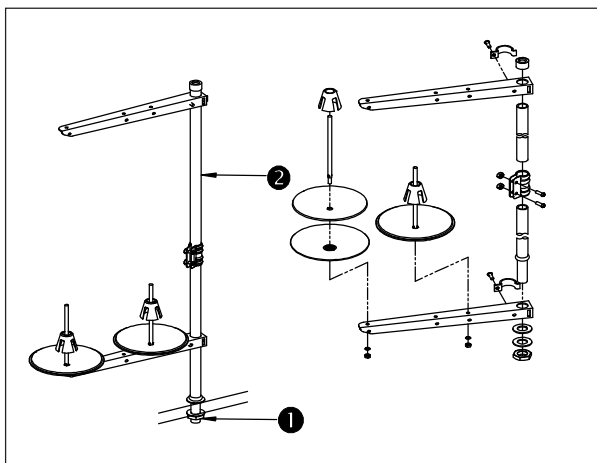

The line frame in the accessory box should be installed in Table.

[4] OPERATION OF THE SEWING MACHINE

1. Lubrication



WARNING :

Turn of the power before starting the work so as to prevent accidents caused by abrupt start of the sewing machine

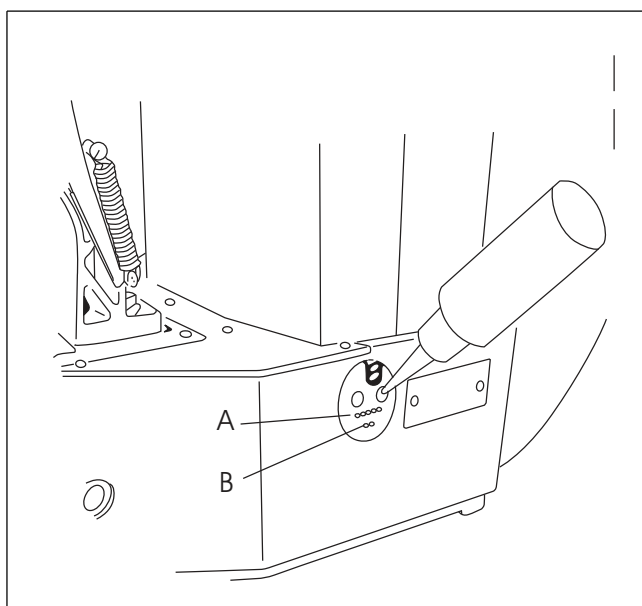

Check that the place between lower line Band upper line A is filled with oil . Fill there with oil using the oiler supplied with the machine as accessories when oil is short.
 *The oil tank which is filled with oil is only for lubricating to the hook portion. It is possible to reduce the oil amount when the number of rotation used is low and the oil amount in the hook portion is excessive.(Refer to 8.Amount of oil supplied to hen kook of [7] maintenance

1. DO not lubricate to the places other than the oil tank and the hook of Caution 2 below. Trouble of components will be caused.



2. When using the sewing machine for the first time or after an extended period of disuse use the machine after lubricating a small amount of oil to the hook portion.(Refer to2.Adjusting the needle-to-shuttle relation of [7]MAINTENANCE

2. Attaching the needle



WARNING : Turn of the power before starting the work so as to prevent accidents caused by abrupt start of the sewing machine

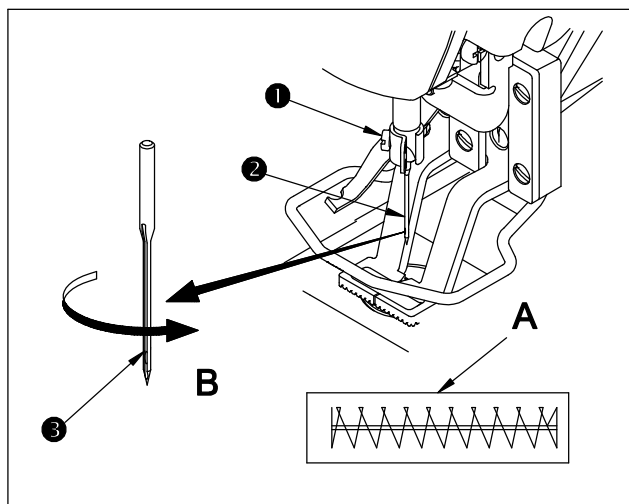

Loosen setscrew① and hold needle② with the long groove facing toward you. Then fully insert it into the hole in the needle bar, and tighten setscrew①.



If the stitches are made as shown in "A", attach the needle facing to the direction "B" to a small extent.

3. Threading the machine head



WARNING : Turn of the power before starting the work so as to prevent accidents caused by abrupt start of the sewing machine

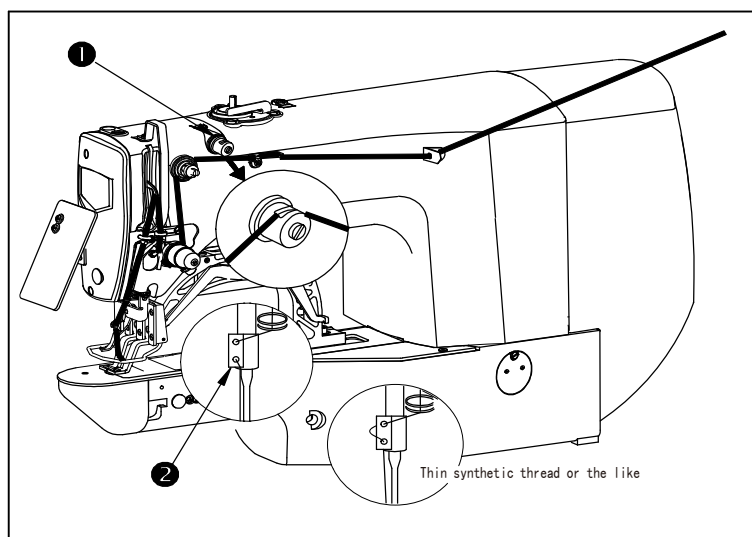

Pull out the thread by approximately 4cm from the needle after threading through the needle.



1. When the silicon oil is used, thread through thread guide for silicon①.
2. For thick thread, pass the thread through one hole only of needle bar thread guide②

WARNING : Turn of the power before starting the work so as to prevent accidents caused by abrupt start of the sewing machine.

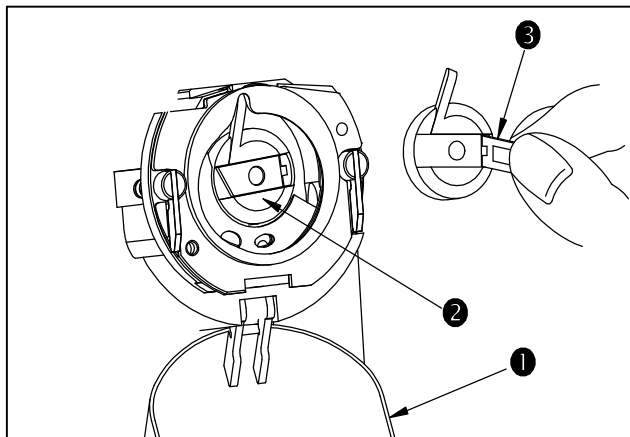

- (1). Open hook cover①。
- (2). Raise latch③ of bobbin case②, and remove the bobbin case.。
- (3). When installing the bobbin case, fully insert it into the shuttle shaft, and close the latch.

Caution If it is not fully inserted, bobbin case ② may slip off during sewing.

5. Installing the bobbin

WARNING : Turn of the power before starting the work so as to prevent accidents caused by abrupt start of the sewing machine

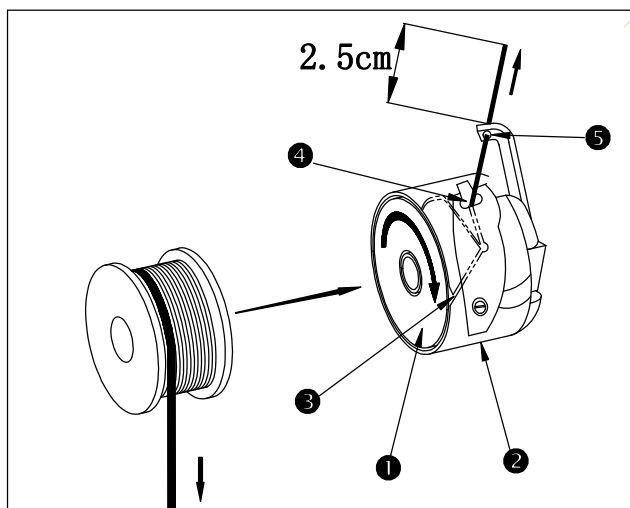

- (1). Set the bobbin ① into bobbin case ② in the direction shown in the figure.
- (2). Pass the thread through thread slit ③ of bobbin case ②, and pull the thread as it is. By so doing, the thread will pass under the tension spring and be pulled out from thread hole ④.
- (3). Pass the thread through thread hole ⑤ of the horn section, and pull out the thread by 2.5cm from the thread hole.

Caution If the bobbin is installed in the bobbin case orienting the reverse direction, the bobbin thread pulling out will result in an inconsistent state.

6. Adjusting the thread tension

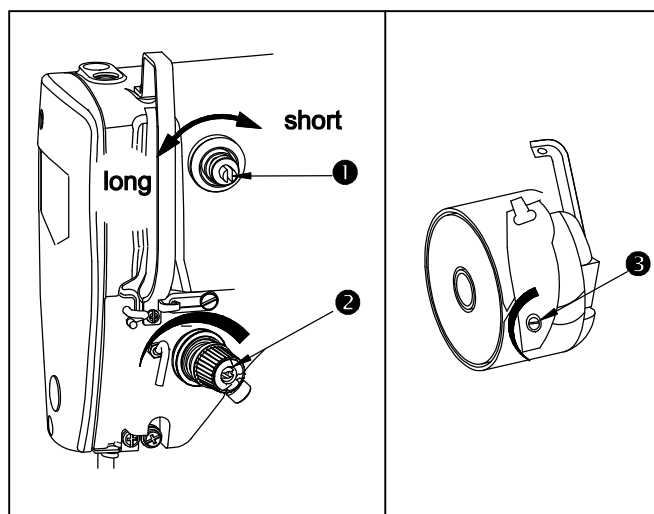

If thread tension controller No.1①is turn clockwise, the length of remaining thread on the needle after thread trimming will be shorter. If it turned counterclockwise, the length will be longer.

Shorten the length to an extent that the thread is not slipped off.

Adjust needle thread tension from the operation panel and bobbin thread tension with②.

7. Adjusting the thread take-up spring

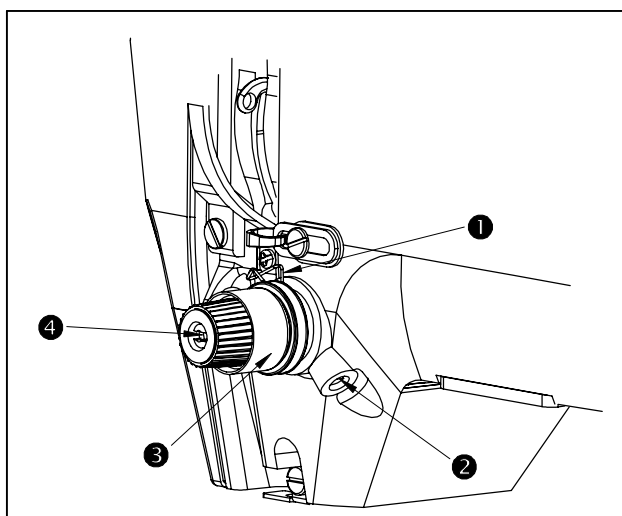

The standard stroke of thread take-up spring ①is 8 to 10 mm, and the pressure at the start is 0.1 to 0.3N.

(1).Adjusting the stroke

Loosen setscrew②, and turn thread tension asm. ③.Turning it clockwise will increase the moving amount and the thread drawing amount will increase.

(2).Adjusting the pressure

To change the pressure of the thread take-up spring, insert a thin screwdriver into the slot of thread tension post④ while screw② is tightened, and turn it. Turning it clockwise will increase the pressure of the thread take-up spring. Turning it counterclockwise will decrease the pressure.

[5] OPERATION OF THE SEWING MACHINE

1. Name & description of buttons on control panel

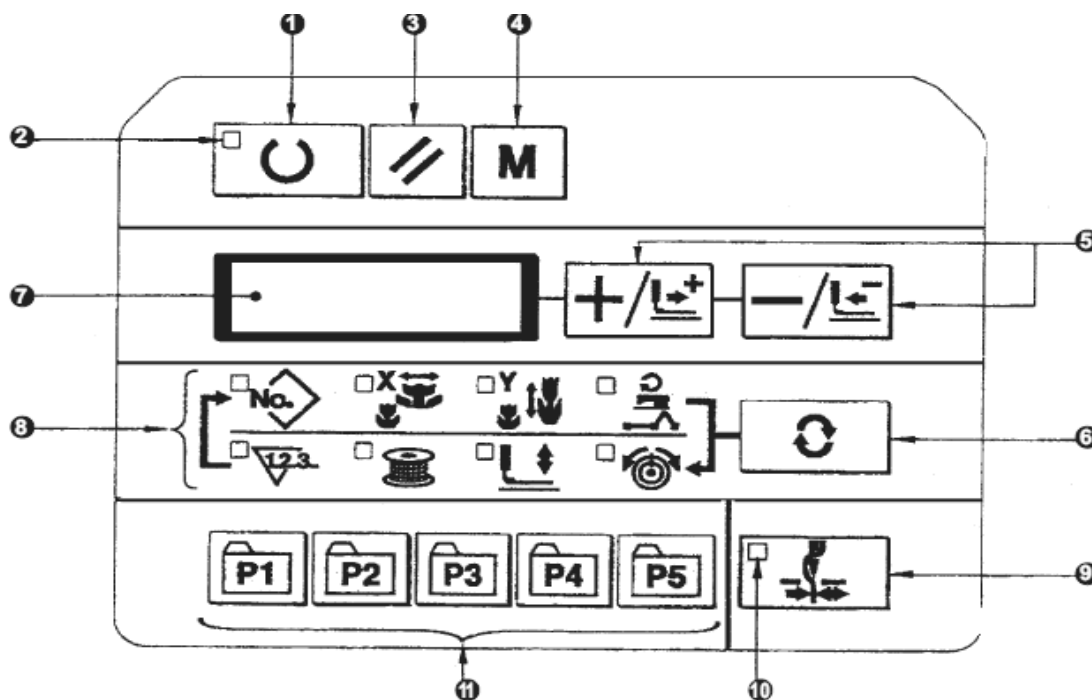

(1).Ready key

Key for shifting between the setting/programming status of control panel and the sewing status of sewing machine;

(2).Sewing LED

It is set as: “ON” at sewing status, “OFF” at programming status. User can use the Ready Key for shifting between these two statuses;

(3).Reset key

Release the error and restore the set value to the default value;

(4).Mode key

When the Sewing LED is off, this key can activate the functions for setting parameters or storing the patterns; when the Sewing LED is on, this key can activate the siding function for threading actions, which will be automatically turned off in 20 seconds.

(5).+/Feed forward key & -/Feed backward key

These two keys are applicable for changing pattern number, rate of scale and feeding cloth forward/backward.

(6).Selection key

Select the set item. The Item Selection LED and the set value of the selected item will be displayed.

(7).Data display LED

This LED indicates the set value of the selected items such as the pattern number, scale rate and so on.

(8).Item Selection LED

The LED of the selected item will be on.

(9).Thread-catching ON/OFF key

The Validity/Invalidity of thread-catching function can be selected. When it is set as Validity, the Thread-catching Display LED will be on.

(10).Thread-catching display LED

When the LED is on, the machine will catch the thread.

(11).Pattern storage key

Store the pattern. The stored pattern can be put into sewing as long as user presses this key. The changes in scale rate, sewing position and so on can also be stored.

※NOTE: Setting the needle thread clamp prohibited with memory switch No35 at the time of standard delivery.

2. Settings of Item Data

Please set the items in the following sequence:

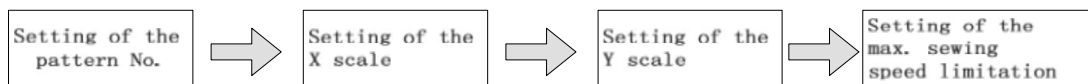



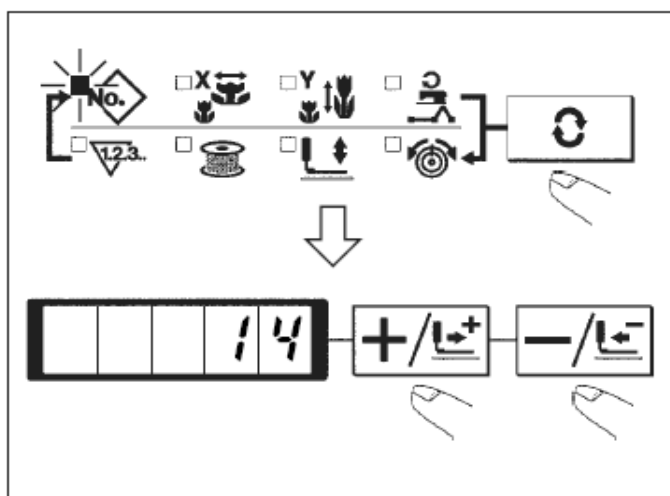

(1). Turn ON the power switch.

The pattern number of the item selection is lit up, and the pattern number will be displayed at data display part.

(2). Setting of the pattern No.





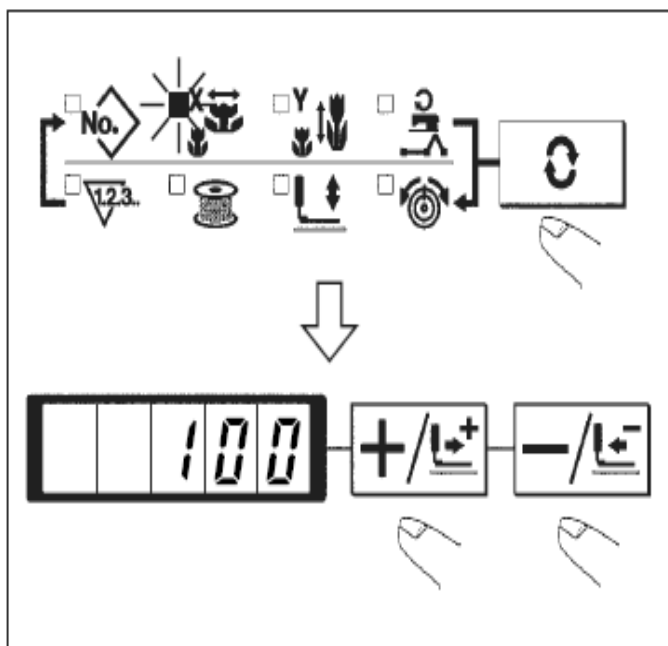

- 1) Press , and then the LED of  will be on.
- 2) Press  and  to display 14 in the Data Display LED

Caution Refer the pattern No. to the separate table.

(3).Setting of the X scale





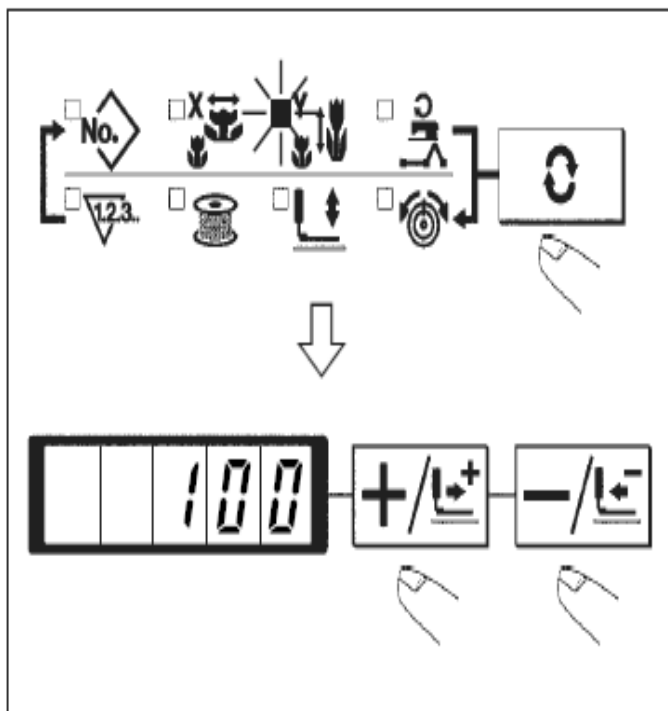

- 1) Press , and then the LED of  will be displayed.
- 2) Press  &  to display 100 at Data Display LED
(The Scale Rate in X Direction is set as 100%)

 The setting exceeding 100% is dangerous since needle and the cloth presser interferes with each other and needle breakage or the like will occur.

(4).Setting of Scale Rate in Y scale





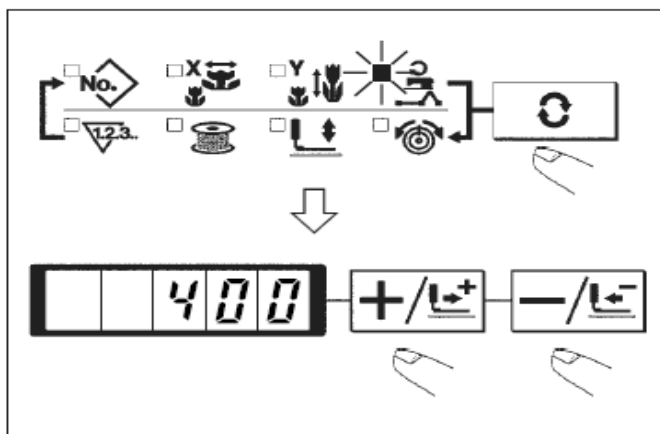

- 1) Press , and then the LED of  will be displayed.
- 2) Press  &  to display 100 at Data Display LED.
(The Scale Rate in Y Direction is set as 100%)

 The setting exceeding 100% is dangerous since needle and the cloth presser interferes with each other and needle breakage or the like will occur.

(5).Setting of Limitation on Max Speed



- 1) Press , and then the LED of  will be displayed.
- 2) Press  &  to display 400 at Data Display LED (The limitation is set as 400rpm)



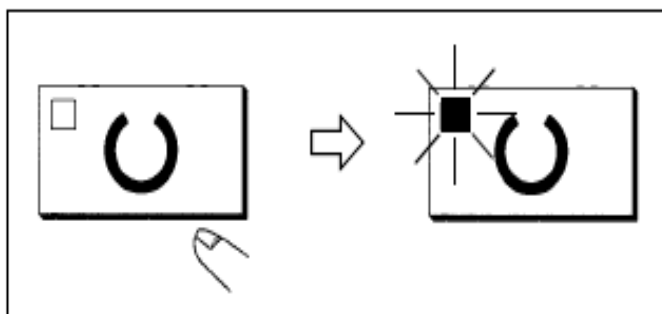

(6). Setting End



- 1) Press .
- 2) After the presser goes up, the Sewing LED is on. At this time the system is in the sewing status.



When the presser is raised, be careful that fingers are not caught in the presser since the presser moves after having lowered.

- Press  to record the set values like pattern number, X/Y scale rate and so on.
- Press  to reconfirm each set item, but the Sewing LED can't changes its status.
- Press  to turn off the Sewing LED, then each set value of item can be changed
- When the pattern number is 0 (the default setting), pressing  will activate the error "E-10". At this time, please press the Reset Key to reconfirm the pattern number.



When turning OFF the power without pressing  key, the set values of pattern No., X/Y scale, number of max. rotation, and thread tension are not memorized.

3. Confirmation of Pattern Shape



After selecting the pattern, user shall confirm the shape of the pattern.
If the pattern is far away from the presser, the needle will run into the presser, thus breaks the needle.

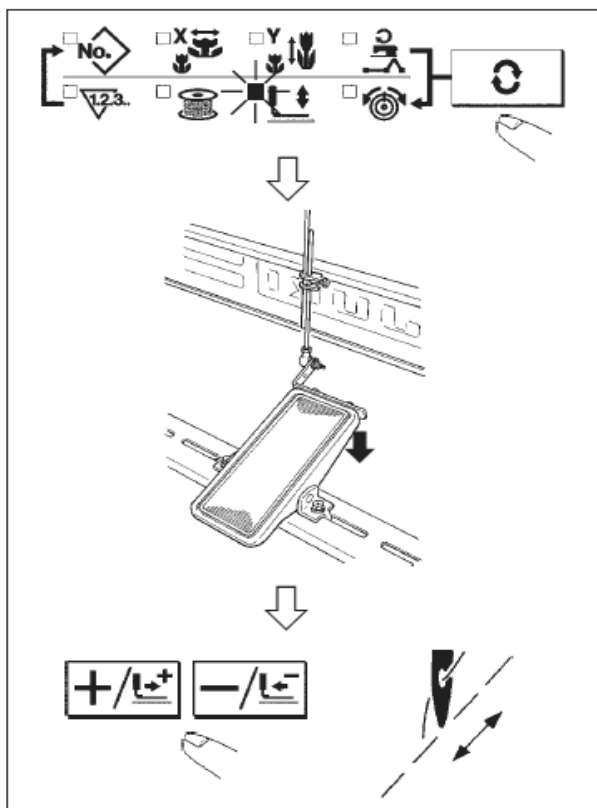

The work clamp feet do not come down immediately after turning ON the power.

- (1) . Press to light up the Sewing LED
- (2) . Press to select , and then the screen displays ; step the pedal to lower the presser and then the screen displays .
- (3) . In the status of lowering the presser, press .
- (4) . Use and to confirm the shape. The confirmed pattern for sewing shall be in the permitted range of the presser.
- (5) . Press to lift presser.
- (6) . Press to release the selection of (select other data item other than). After that, press to end the trial sewing and the Sewing LED will be off.

4. Sewing

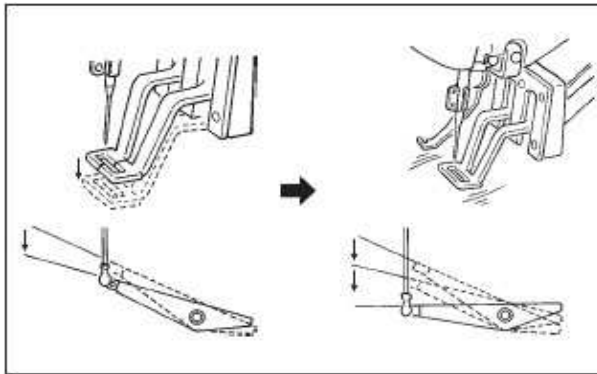

- (1) .Put the fabric to the presser section
- (2) .Step on the pedal switch to the level 1, then the presser goes down. If you detach the foot from the pedal, the presser will go up.
- (3) .Lower the presser to the next level, and then depress the pedal to the second level to start sewing
- (4) .At sewing end, the presser will go up and stop at the initial position.



Attention 1: When depressing the pedal to level 1 and lowering the presser, the user can

press $\boxed{+/L^+}$ & $\boxed{-/L^-}$ to change the sewing position of pattern. Then the user could start sewing at the selected position by depressing the pedal to level 2. During the sewing, for the problems like thread-breakage, user can use this method for mending after releasing the malfunction

Attention 2: Don't apply the operations in Attention 1 into the operation of pattern trial sewing, in case the user depresses the pedal to level 2 by mistake, thus start the machine and cause the dangerous. For the operations in trial sewing, user shall strictly follow the descriptions

5. Change to other patterns

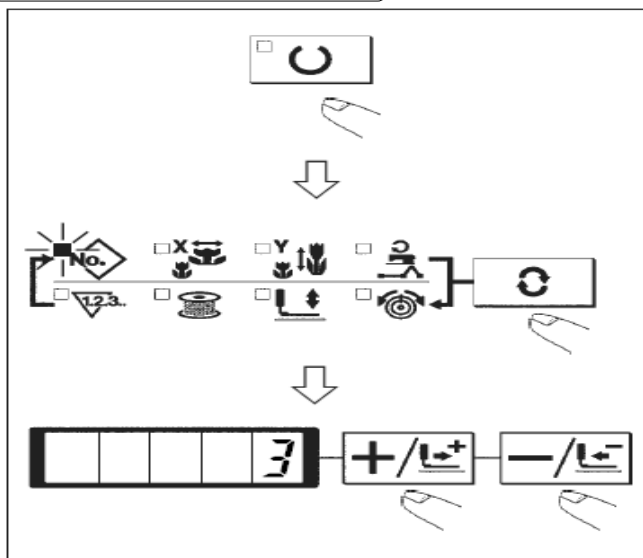

- (1) . Press $\boxed{\text{OFF}}$ to turn of the Sewing LED.
- (2) . Press $\boxed{\text{No.}}$ to select the $\boxed{\text{No.}}$.
- (3) . Use $\boxed{+/L^+}$ & $\boxed{-/L^-}$ to set pattern number.
- (4) . Set the X/Y scale rate, speed and so on in the same way
- (5) . Press $\boxed{\text{ON}}$ to turn on the Sewing LED, thus have access to Sewing status.









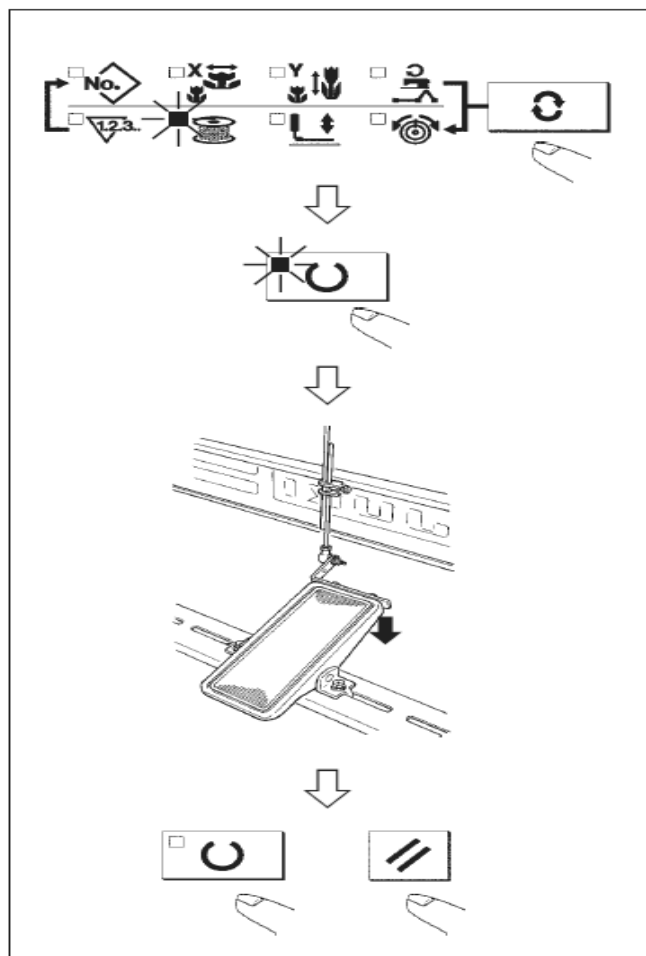

After selecting the pattern, user shall confirm the shape of the pattern.

If the pattern is far away from the presser, the needle will run into the presser, thus breaks the needle.

6. Winding



The winding device will not work just after power-on. Please set a pattern code and press  to turn on the Sewing LED before the winding operation.

- (1) . Press  to turn off Sewing LED.
- (2) . Press  to select the . (It is unable to select when the Sewing LED is on.)
- (3) . Press  to lower the presser and turn on the Sewing LED.
- (4) . Depress the pedal to start the sewing machine
- (5) . Depress the pedal switch or press  or  to stop machine.
- (6) . Press  to turn off the Sewing LED and lift the presser. Then  become valid.

7. Independent thread-trimming device



Independent thread-trimming, different from the general presser transmission and main-shaft transmission thread-trimming mechanisms, has the independent control unit, which can control the whole process of thread-trimming better,

If the storage parameter No.35 is set as 1 (Thread-trimming Forbidden), the machine will not perform the thread-trimming.

8. Thread-catching device

With thread-catching device, the abnormal sewing, like the missing or staining of upper thread, as well as needle-jumping, can be avoided in the high speed start. The thread-catching function is only available when the Thread-catching Display LED is on.

User can use  to turn on/off this function. When the thread-catching device is OFF, the machine will turn to low-speed start automatically.

 **The thread-catching action will be invalid if the Storage Parameter No.35 is set as 1 (Thread-catching Forbidden). At the same time,  becomes invalid.**

Matters for attention in using the function for catching upper thread

(1). For catching thread, please shorten the upper thread at sewing start.

If the needle is too long, the thread at the backside of the cloth will be pulled out; meanwhile that too-long needle will easily sew the end of the thread on needle into the seam.

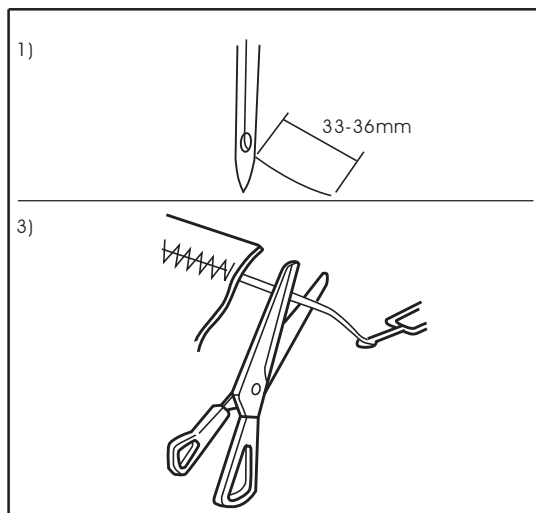

- 1). The standard length of needle thread in thread-catching shall be 33~36mm.
- 2). Lengthen the thread after replacing the needle thread. Or when holding the needle thread at sewing, please set the Thread-catching Key at OFF.
- 3). When the needle thread held with the thread catcher is rolled in the seams, do not draw the material forcibly but cut the connecting needle thread with the scissors or the like. The seams are not damaged since it is the needle thread at the sewing start.

(2). In order to make thread-catching action ensure the stable sewing at start, user can shorten the needle so that less needle thread could be winded in upper side of the cloth.

(3). When the type of lower plate (1) that material doesn't closely contact to the board (2) is used, needle thread at backside of cloth will be rolled into the seams regardless the length of the thread or the needle thread will be loose

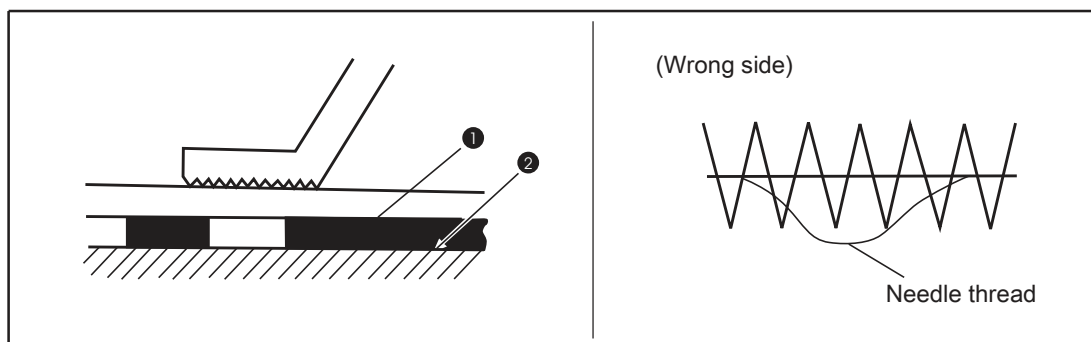

9. Bottom thread counter

The counters are set as Production Counter (Adding method) at the time of delivery. However, if it is used as the Bottom Thread Counter (subtracting method), the value of parameter No.18 shall be set at 1.

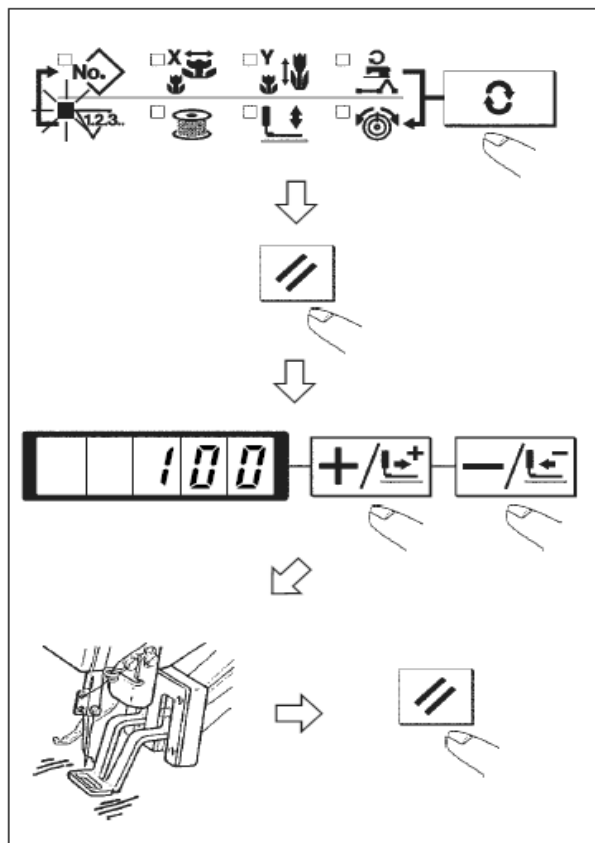

- (1) . Press to select .
- (2) . Then press .
- (3) . After that, press & to set number of times that can be sewn with a bobbin.
- (4) . Finish of sewing in each time will cause the counter to count down by one
- (5) . After the machine finishes the set times of sewing, the monitor will shine for hinting the user.
- (6) .Replace the bottom thread and press again. Then the value of counter will restore to the set value (Repeat the steps from (4) to (6)).

10. Pause



After user set the value of No.31 parameter at 1, or the reverse gear of pedal can be used as the pause key.

- (1). If user presses or depresses the reverse gear of pedal, the sewing machine will stop and display the error No.50.







- (2). The following are the three available operations after the pause:
错误! 未找到引用源。 Press the Start Switch to start the sewing.





错误! 未找到引用源。 Press and perform the thread-trimming. After that, use & to adjust the position and then press start switch to start sewing.

③ Press  and trim the thread. After that, press  again to return to the origin.

11. Set P pattern & C pattern

11-1. Use Pattern Key (    ) for Sewing

The saved patterns (No.1~200) can be registered on P1~P50. It is possible to change and register the scale rate, Max speed limitation and sewing position. With the rolling window of pattern, user can also register patterns and has access to the pattern from P1~P25 at a time.

· For selecting P6~P25, user can use the combinations of      (simultaneous pressing) shown in the below table at his sewing.

P-No	Selection Key	P-No.	Selection Key	P-No.	Selection Key	P-No	Selection Key
P1	P1	P8	P1+P4	P15	P4 +P5	P22	P2+P3+P4
P2	P2	P9	P1+P5	P16	P1+P2+P3	P23	P2+P3+P5
P3	P3	P10	P2+P3	P17	P1+P2+P4	P24	P2+P4+P5
P4	P4	P11	P2+P4	P18	P1+P2+P5	P25	P3+P4+P5
P5	P5	P12	P2+P5	P19	P1+P3+P4		
P6	P1+P2	P13	P3+P4	P20	P1+P3+P5		
P7	P1+P3	P14	P3+P5	P21	P1+P4+P5		



(1).Registration on pattern key

Exp: Register pattern No.3 to P2, X scale rate: 50%; Y scale rate: 80%; Max speed limitation: 2000 rpm, pattern position: 0.5mm to the right and 1mm to the front.

1). Turn on the power, press

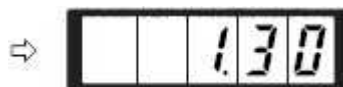
 (the sewing LED shall be off at this moment) to have access to Mode Setting (Setting of Storage Switch).









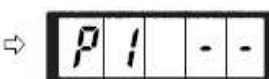



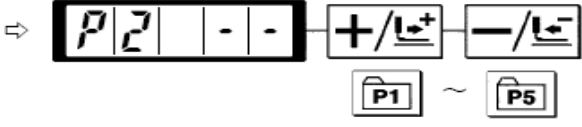











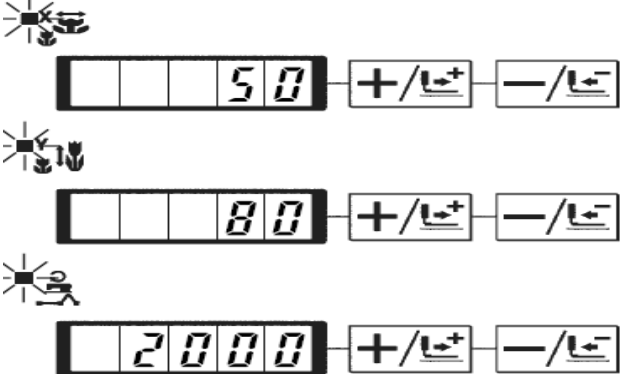





2). Use  &  to display the storage mode of pattern

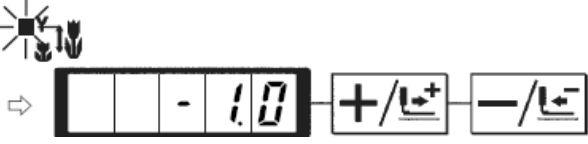

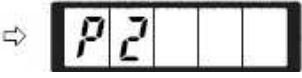
3). Press  to have access to the pattern storage mode.

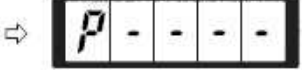

- 4). Press  to select the stored P-No.
 This selection can also be done by using  &  .

- 5). Use  to select  .
 Use  &  to set pattern number.

- 6). Press  and use  &  to set the X scale rate  at "50%" and the Y scale rate  at "80%", as well as Max Speed limitation  at "2000"rpm.

- 7). Press  to activate X scale rate  ,which is displayed at 0.0. The stroke in X direction can be changed in step at 0.1mm. Use  &  to set this value at 0.5.

- 8). Press  to activate Y scale rate  , which is displayed at 0.0. The stroke in Y direction can be changed in step at 0.1mm. Use  .

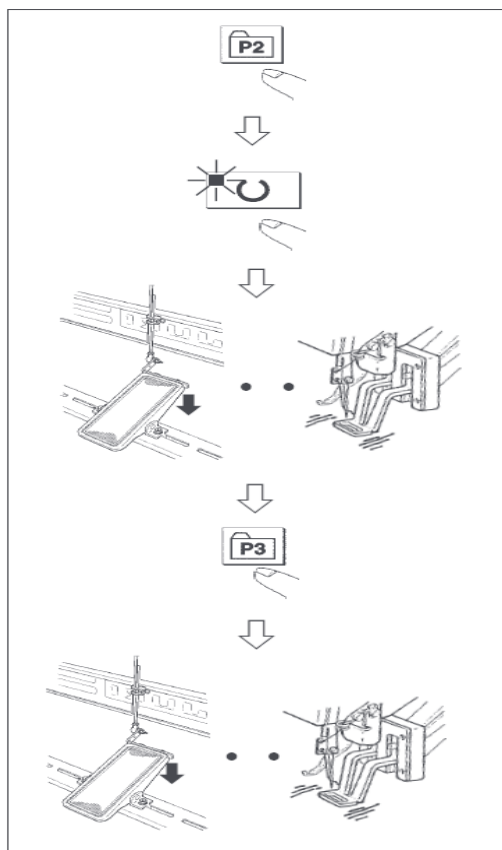
- 9). Press  to end the setting.

- 10). Press  to end pattern storage mode

- 11). Press  to end Mode Setting and return to Ordinary Mode



(2).Sewing operation

Example: sew the pattern saved as P2 at first, and then sew the P3.

Press P1 to P25 key while the sewing LED lights up and the presser comes down.

Be careful that your fingers are not caught in the presser. Pattern register from P26 to P50 can be performed. Register can not be performed in P1 to P5 key. Designate the pattern by the pattern selection only. Indicate the pattern with or key. Pattern selection from P26 to P50 cannot be performed while the sewing LED lights up.



- (1) . Turn on the power.
- (2) . Press .
- (3) . Press  to turn on the Sewing LED, and then the presser will go up.
- (4) . Confirm the pattern shape.
- (5) . If the pattern shape is correct, the machine will be able to carry out the sewing.
- (6) . After sewing, please press  to lower the presser for searching the origin. After that, the presser will move to the sewing start point and go up. (When the Sewing LED is on, user can also press P keys to change the pattern.)
- (7) . Perform the operations in Step 4 and Step 5.

11-2. Sewing with combination functions

Store the patterns registered in the sequence as P1~P50 to C1~C20. The sewing pattern will be changed in order upon the finish of sewing in each time. 30 patterns can be stored in a combination code at most.

(1).Storage of combination pattern

Example: Register the combination in order of P1, P2 and P3.

1). Turn on power. Press **M** to have access to Mode Setting (for setting parameter of memory). The Sewing LED shall be off at the moment

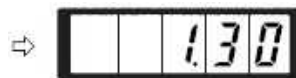

2). Use **+/-** & **-/-** to display the Combination Mode



3). Press **⏻** to turn on the Sewing LED, thus to have access to the setting mode of combination pattern. User can select C pattern number from C1~C20 with **+/-**

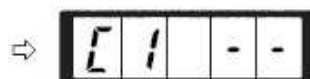

4). Press **0** and **P1** to set the P1 as the first pattern in the C1. User can select P pattern from P1~P50 with **+/-**

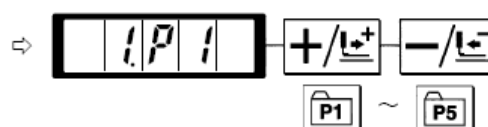

5). Press **0** and **P2** to set the P2 as the second pattern in C1. User can select P pattern from P1~P50 with **+/-** & **-/-**.

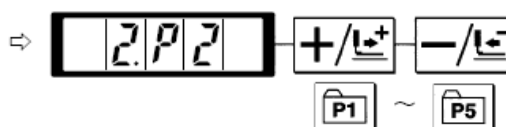

6). Press **0** and **P3** to set the P3 as the third pattern in C1. User can select P pattern from P1~P50 with **+/-** & **-/-**.

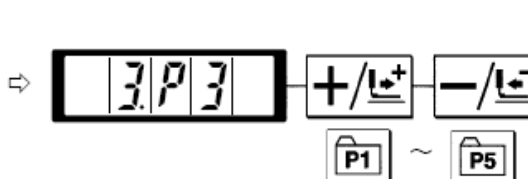

7). Press  to end the storage

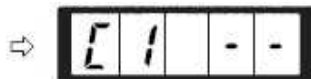

8). Press  to end the storage mode of combined pattern.

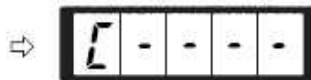

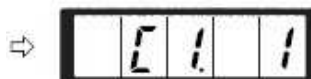

9). Press  to end the Mode Setting and return to the ordinary mode.



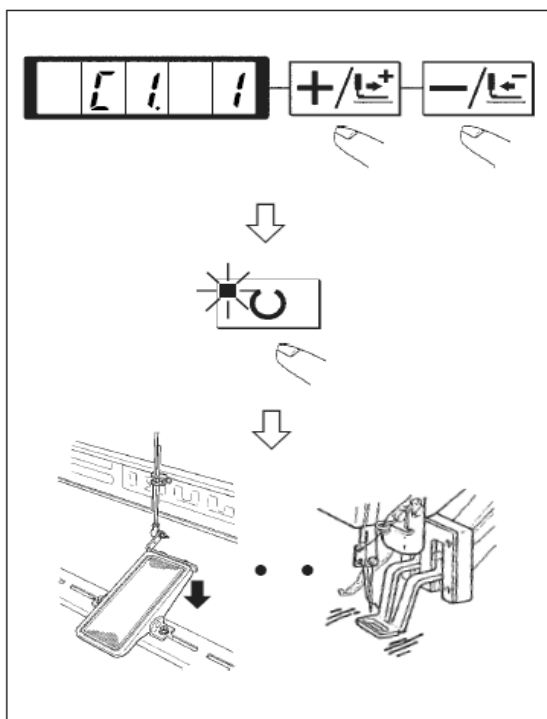

(2).Sewing operation

Example: Sew the C1 pattern.







- (1) . Power on the machine
- (2) . Set the pattern number as C1.1 with  & .

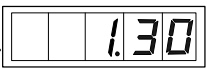

- (3) . Press  to turn on the Sewing LED. After that the presser will go up.
- (4) . If the pattern shape is sound, the sewing operation will proceed.
- (5) . Sew the C1 pattern in the sequence in the combination. When the last pattern in the combination is finished, the machine will start sewing the first pattern and repeat this combination.

- ◎ After the sewing, if user wants to go to the previous pattern or the next pattern, user can press  &  when the Sewing LED is on. Then the pattern display will be changed and the presser will also move to the start point
- ◎ After storing the patterns among C1~C20, if the P pattern in P1~P50 id changed, the content of P pattern with same code will also be changed.。
- ◎ Confirmation of pattern is necessary for each pattern.

12. Debugging mode

Via this mode, user can perform the operations of maintenance and checking.

(1) . When the Sewing LED is off, press  to call the display of . Then press    at same time. After the ring of buzzer, the system will have access to the debugging mode via the user level setting mode of memory switch.

((Attention)) Not pressing    at same time will cause the failure of access to debugging mode.

(2) . Press  to have access to debugging mode, the monitor will show “CP---” as



displayed in the following picture:  ;  ;

(3). Press  to perform the display output test. This test will check the display module and indicator of each LED in cycle; the following is the specific procedure:

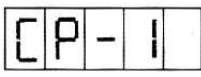
(4). Press  again to end the display output test. The monitor will display “CP-1” as

shown in the following picture: .

 Only after the display output test, can the user perform the test on other functions.

(5). Press  &  to change the program code of the function test. The function stood by each code is shown in the following table:

(6). Hold  to have access to the function test.

(7). During the function test, if user presses , the test will be stopped and the system will return to the status of 5); However, if the continuous mode has been used for once, the test will be unable to be released. For ending the test, the user can only turn off the power.









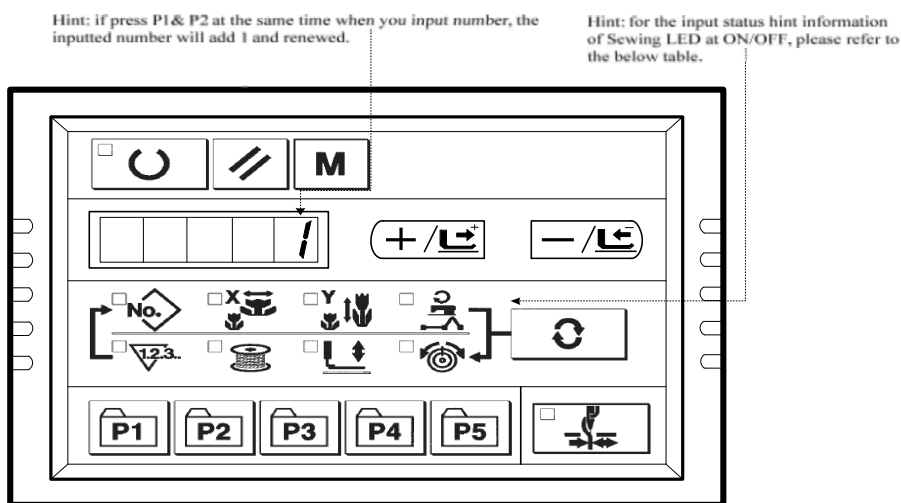



Function Test Code	Function	Content
CP-1	Test input signal	LED hint switch, sensor input
CP-2	X/ Y Motor Origin Sensor Test	Display the statuses of the X/Y motor step motion operation, origin searching operation and X/Y origin sensor.
CP-3	Continuous Running	If setting the condition of continuous running, test the continuous running mode.
CP-4	Main motor rotation number test	Setting rotation number, machine start-up ,display of actual rotation number
CP-5	thread-trimming test	Action of thread-trimming motor, debugging the installation of knife
CP-6	Presser foot motor /origin sensor test	Display the step motion of presser foot motor, operation of origin searching, and the status of presser origin/presser sensor.
CP-7	Thread-catching motor/origin sensor test	Display the step motion of thread-catching motor, operation of origin searching and the status of thread-catching origin/thread-catching sensor.
CP-8	_____	_____

12=1.CP-1 Input signal test

Test the input status of the buttons, pedal and sensors. Press  to have access to CP-1 when the “CP-1” is displayed at the screen. After that, the screen displays the “1” that means the first test content.





The display content for each inputted No.

Input No.	Pattern NO. LED	X Scale LED	Y Scale LED	Speed LED	Counter LED	Winding LED	Presser-lowering LED	Solenoid LED
1	/	/						
2	/	/						
3	/	/	/	/	/	/	/	/
4	Pedal Level 0	Pedal Level 1	Pedal Level 2	/	/	/	/	/
5	Presser motor origin sensor	Y motor origin sensor	X motor origin sensor	Thread-cutting origin sensor	Thread-trimming sensor	Thread-cutting sensor	/	/
6	Main-shaft angle display							
7	Main-shaft motor Z phase	/	/	/	/	/	/	/
8	/	/	/	/	/	Head tilt switch	/	/

12-2. CP-2 Check X/Y motor/origin sensor

Display the statuses of X/Y origin sensor, operation of searching origin and step operation of X/Y motor.

(1).Preparation

Press  to have access to CP-2, and system displays “1” at screen. Then press  to search the origins of X/Y motors. At that time, the presser goes down and the Sewing LED is on (User can also perform step 2 directly without pressing ).

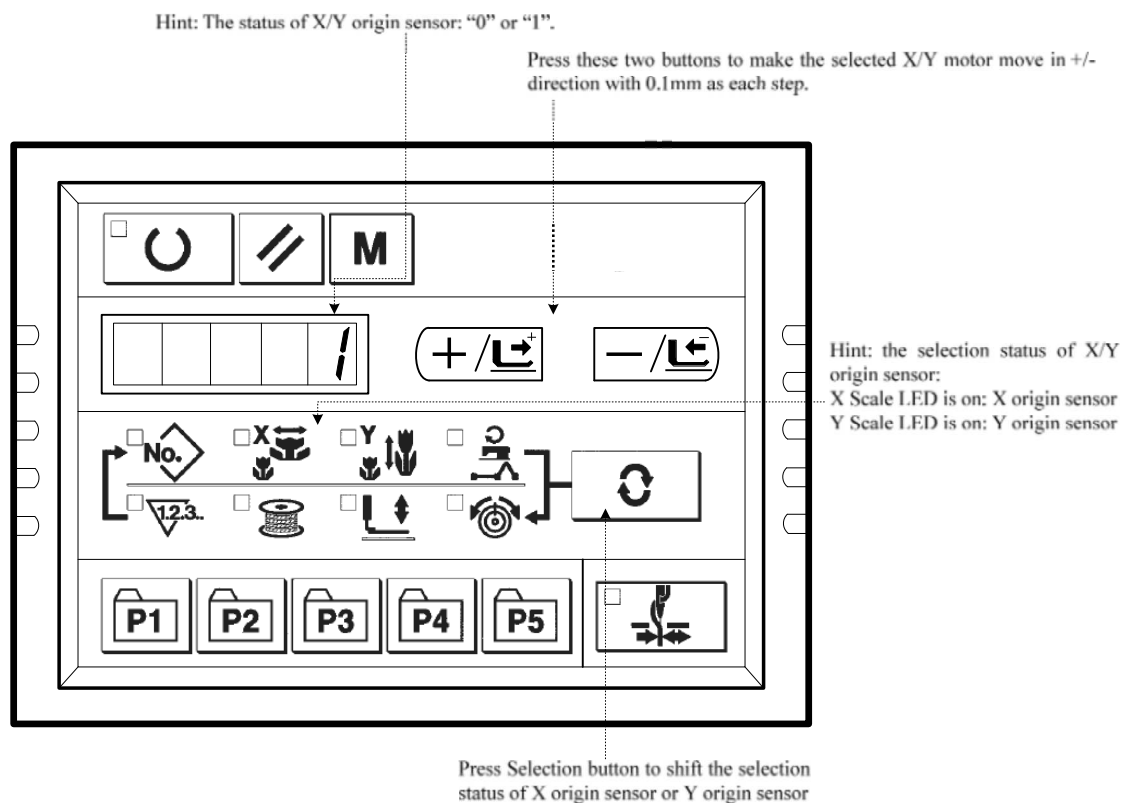

(2).Operation



12-3.CP-3 Continuous running

When the screen displays the "CP-3", user can press  to have access to the Continuous Running Mode. After setting the conditions for continuous running, user can start the continuous running mode; for quitting the continuous running mode, please turn off the power.



(1).Setting of time interval

User can press  &  to set the time interval between two operations.

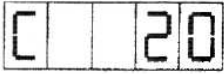
From 1800ms to 9900ms, user can set the 100ms as a changing step. After the setting (the

default value is 2000ms), user can press  to save the set value .

(2).Setting of origin search at sewing end.

User can press  &  to set the validity of origin search at sewing end.

A0: Invalid (Default value)

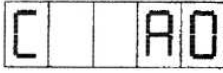
A1: Valid(Search origin after sewing at each  time)

After the setting, user can press  to have access to the normal sewing mode.

(3).Continuous operation

Under the normal sewing mode, user can set the conditions, such as pattern number, X/Y scale rate and Max speed, and start sewing. At sewing end, if the user sets the origin search at the second step operation, the machine will search the origins of motors, including X/Y presser motors, thread-trimming motors and thread-catching motor; however, if the user set stop time in the 1st step operation, the machine will automatically start sewing again after sewing end.

For stopping the continuous sewing, please press  when the sewing ends.

12-4. CP-4 Test main motor speed

Set the speed of machine. With the set speed, the machine will only run the main motor that is used for driving the machine and display the actual speed.







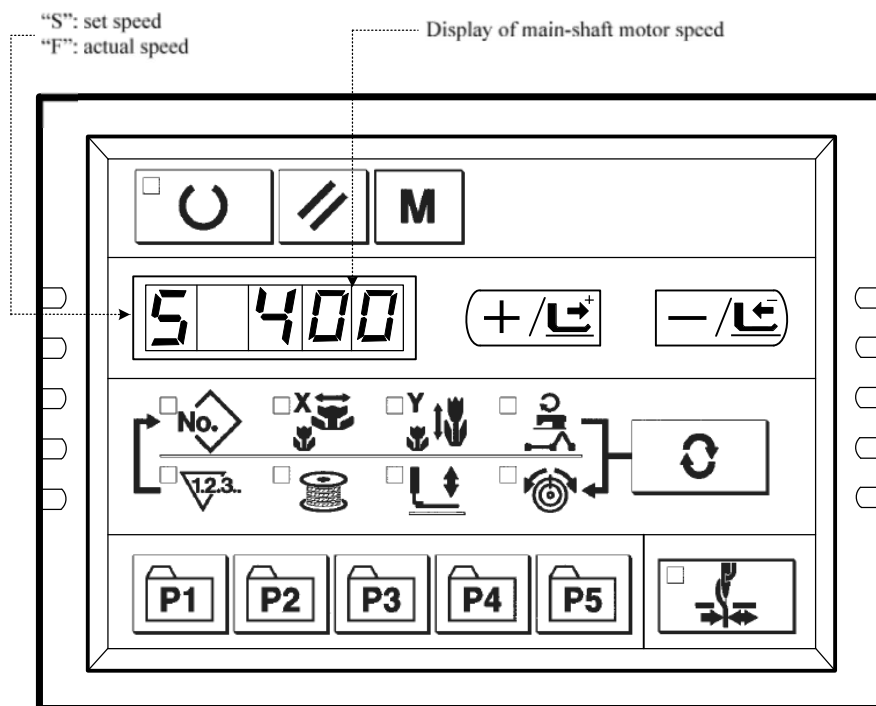



(1).Preparation

User shall press  to have access to CP-4 firstly. At this time, the screen displays

“S400”. Then the user can press  to search the origins of motors, including thread-catching motors, presser motors, and thread-trimming motors. At this moment, the Sewing LED is on.



(2).Operations

User can use  &  to change the setting on the main-shaft speed. Then the machine will run in the set speed just after user presses . At this time, by pressing , user can shift the display of set speed and the display of actual speed. For changing the set speed again, user shall press  again and use  &  to set the speed, and then press  to enable machine to run in the newly set speed. Press  for stopping while pressing  for quit.

By pressing this key, user can let machine run in the set speed. For changing the speed, please press.

By pressing this key, user can stop the machine.

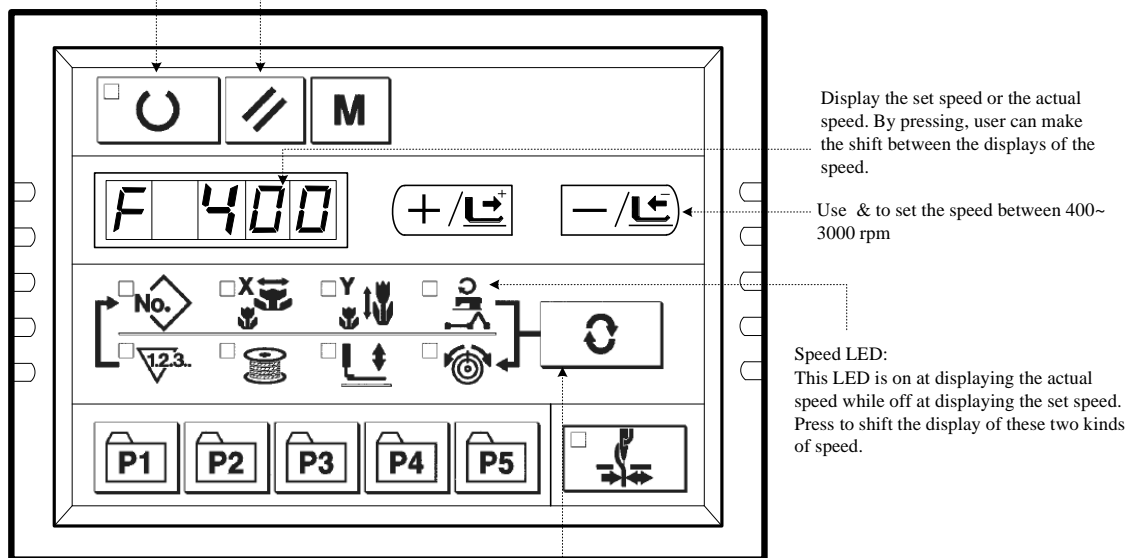

By pressing this key, user can make the shift between the displays of the speed.

12-5. CP-5 Adjustment on thread-trimming

Display the step motion of thread-trimming motor and the thread-trimming actions of moving to thread-curving position, thread-trimming, knife return, and return-to-origin.

(1).Preparation

Press  to have access to CP-5.

(2).Operation

1). Operation of step motion of thread-trimming motor



User can press **+ / L⁺** & **- / L⁻** to operate the step motion of thread-trimming motor.

This function is for the staffs at their installing and debugging the knife.

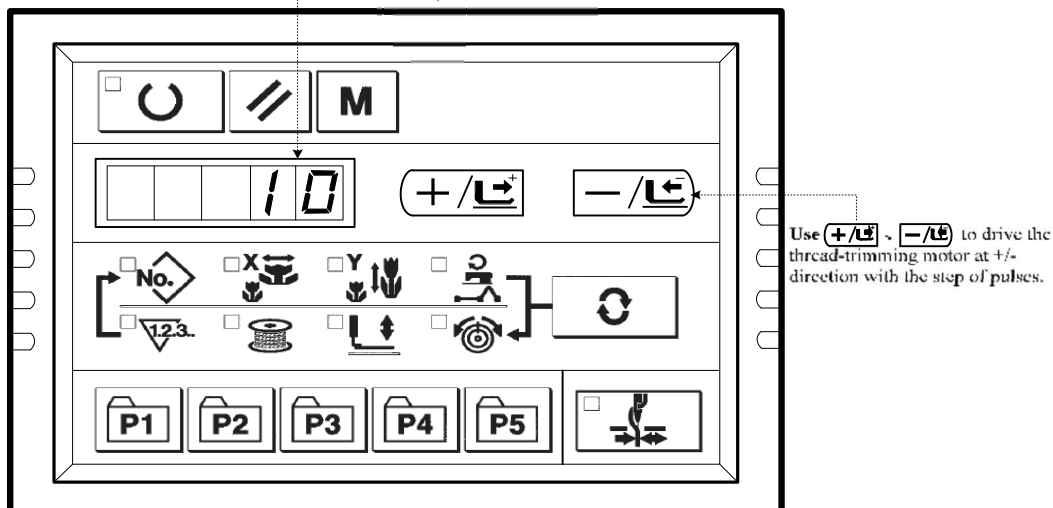
Status of thread-trimming sensor: "00" light-shield works
 "10" light-shield not works



2). Thread-trimming action

Press **π**  to turn on the Sewing LED, and then depress the pedal for searching the origin; by pressing **0**  for times, users can let the thread-trimming motor perform the four actions, such as motion to thread-curving position, thread-trimming, knife return, and return-to-origin. For quitting this mode, please press **M** .

Status of thread-trimming sensor: "00" light-shield works
 "10" light-shield not works

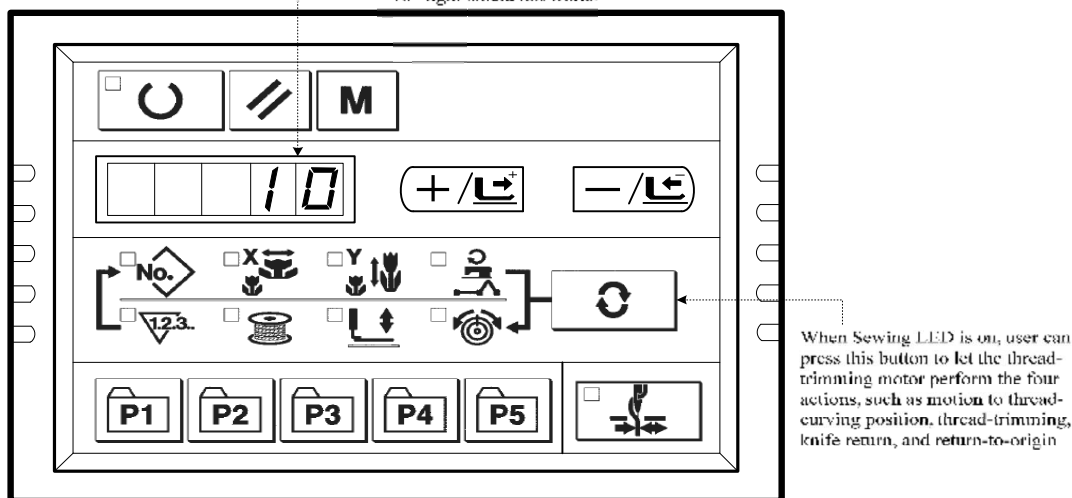



12-6. CP-6 Test presser origin sensor

Display the step motion operation of presser motor, operation of origin search and status of presser origin sensor.

(1).Operation

1). Preparation



Firstly, user can press  to have access to CP-6. Then user can press  to search the origin of thread-catching; at this time, the sewing LED is on.

2). Operations

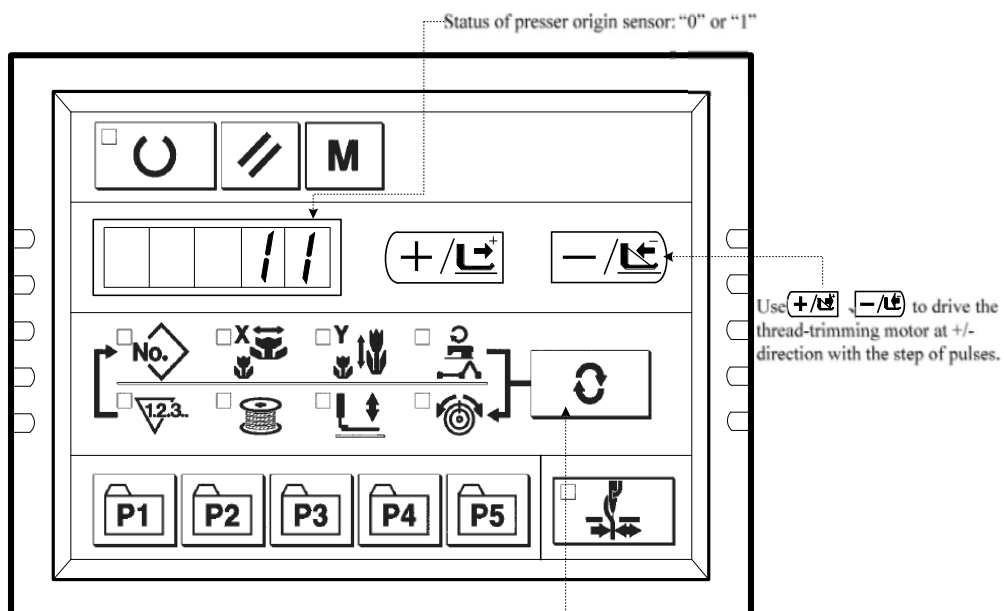
If the user presses  for 6 ~ 8 times, and then the display on screen changes to “01” from “00”, it means the presser sensor is normal. If not, please adjust the position of the presser sensor.





By pressing , user can drive the presser motor to each pointed position:
 1. Presser up position
 2. Presser down position (lowering position during the operation of pedal);
 3. Thread-trimming position
 4. Presser down position (lowering position after thread-trimming)
 5. Thread-string position

After user presses , the relating parts on the machine will do the 5-step cyclic action in the sequence shown in above figure. Press  to quit that mode.





12-7.CP-7 Test Thread-catching motor/ origin Sensor

Display the step operation of thread-catching motor, the statuses of thread-catching motor origin sensor and thread-catching sensor and operation of origin search.



(1). Preparation

Firstly, user shall press  to have access to CP-7; then press  to turn on the Sewing LED. Depress the pedal to search origin. After that the screen will display “10”.

(3) . Operation

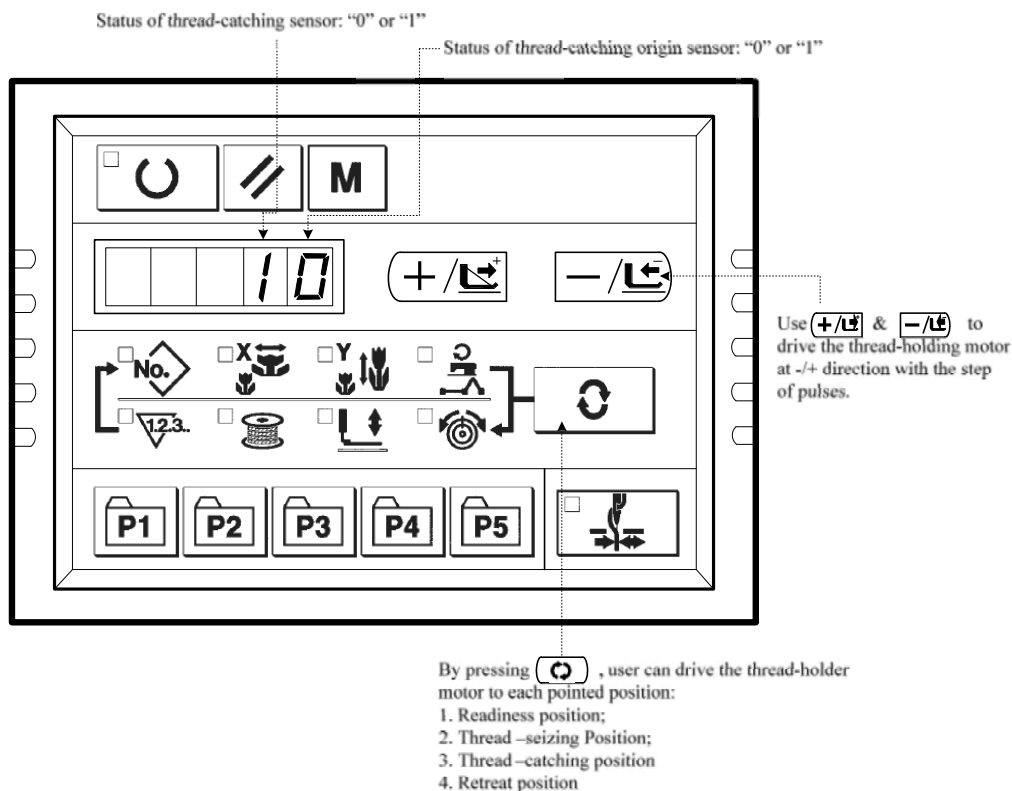
By pressing  & , user can let thread-catcher move in step with the pulse as unit. Press  to drive the thread-catcher backward; press  to drive the thread-catcher forward.



After user presses , the relating parts on the machine will do the 4-step cyclic action in the sequence shown in above figure. Press  to quit that mode.

13. Parameter setting

13-1. Specific operations on setting parameters

(1) . When Sewing LED is off, user can press **M** to set the parameters.

((After user presses **M** , the displayed 1.30 means that the Max speed of the No.1 parameter is 3000rpm.))

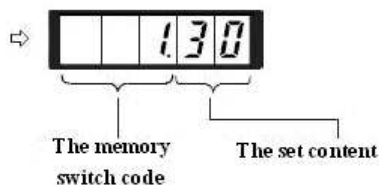

(2). User can use **+/-** & **-/-** to change the number of parameter.



(3). By pressing **⏻**, user can adjust the wanted parameter number and turn on the Sewing LED

(4). By using **+/-** & **-/-** , user can change the corresponding value of the parameter



(5). By pressing **↘**, user can make the parameters return to the initial value.

(6). By pressing **⏻**, user can save the changed content and turn off the Sewing LED. After that, the machine returns to parameter number selection status.

(7). Pressing **M** will end the parameter setting mode and let system return to ordinary status.

13-2. Example for setting parameters

(1). Setting of max sewing speed

Emp.: Set the upper limitation of sewing speed to 1800rpm



1) When the Sewing LED is off, user can press **M** to display the content of Parameter No.1. Parameter No.1 displays the Max speed of sewing machine.

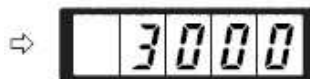

2) When the No.1 parameter is displayed;

user can press  to turn on the Sewing LED. Then the content of No.1 parameter is displayed in the screen.



3) User can use  &  to set the speed to “1800”



4) Press  to save the value and turn off the Sewing LED.

5) Press  to return to the ordinary status.

(2).Setting of soft-start speed at sewing start

The speed of stitches from the first one to the fifth one can be set in the unit of 100rpm. User can also set the validity of thread-catching on these stitches.

With thread-catching function

	Default Setting(rpm)	Setting Range
1st stitch	1200	400~1500
2nd stitch	2500	400~3200
3rd stitch	2700	400~3200
4th stitch	3000	400~3200
5th stitch	3200	400~3200



For the Max speed, the No.1 parameter takes the priority.

Emp.: In case of having thread-catching function, the 1st stitch will change from 1500 to 1000rpm, while 2nd stitch will change from 3000 to 2000rpm.

1) When the Sewing LED is off,

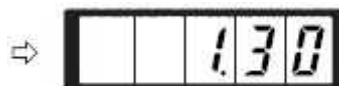
press .





2) By using  & , user can have the parameter code No.2 displayed. And user can set the sewing speed of 1st stitch



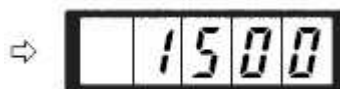

3) Press  to turn on the Sewing LED and display the set value of the 1st stitch.





4) By using  & , user can input “1000” in the screen. Press  to return to default setting. If

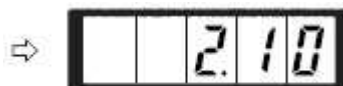

user presses , the existing operations will be cancelled and system will return to the status in step 2).

5) Press  to turn on the Sewing LED and save the set value of the 1st stitch.







6) By pressing the  & , user can display the parameter code No.3 at screen. And the sewing speed of the 2nd stitch is display at here as well.

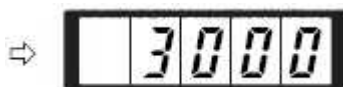



7) Press  to turn on the Sewing LED and display the set value of the 2nd stitch.



8) By using  & , user can input “2000” in the screen Press  to return to default setting. If user presses , the existing operations will be cancelled and system will return to the status in step 6).





9) Press  to turn off the Sewing LED and save the set value of the 2nd stitch. ⇒ 



10) Press  to end the parameter setting mode and return to the ordinary status.



[3]. Setting on whether to call the pattern number



User sets the machine not to read the inoperative pattern in case the unnecessary pattern is called. Additionally, the available pattern can be called when necessary.

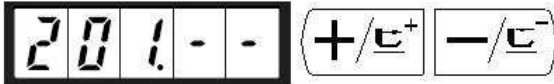

Emp.: Set the No.2 & No.3 patterns as the inoperative.



1. Press  when the Sewing LED is ⇒ 

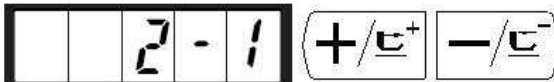

2. User can use  &  to let screen display parameter code No.201. ⇒ 

3. Press  to turn on Sewing LED, at the same time the set value of pattern No.1 is displayed. Set value 1: Readable; 0: Unreadable. ⇒ 

4. Set pattern No. 2 with  & . ⇒ 

5. Set the value to 0 with . ⇒ 

6. Set pattern No.3 with  & . ⇒ 

7. Set the value to 0 with . ⇒ 

8. Press  to save the set value and Turn off the Sewing LED



9. Press  to end the parameter setting mode and return to ordinary mode.

[4] Setting of counter action



The production counter can be used as the Bottom Thread Counter. In repetition sewing, if a bobbin finishes the sewing time as set in parameter, the sewing machine will stop sewing. The Bottom Thread Counter uses the subtracting method.

The counters are set as Production Counter (Adding method) at the time of delivery. However, if it is used as the Bottom Thread Counter (subtracting method), the parameter switch No.18 shall be changed.

Example: change the Production Counter (Adding method) to Bottom Thread Counter (Subtracting method).

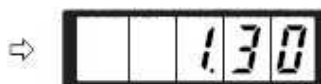
1. Press  when Sewing LED is off.



2. User can use  &  to let screen display parameter code No.18



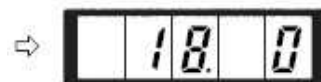

3. Press  to turn on the Sewing LED.
Then the set value of the counter action is displayed in the screen.



4. Set the set value to 1 with 
Set value 0: Production Counter;
1: Bottom Thread Counter



5. Press  to save the set value and turn off the Sewing LED

6. Press  to end the parameter setting mode and return to ordinary mode.

13-3. Table for parameter setting

No.	Functions	Adjustment Range	Default Value	Remarks
1.30	Max Speed of Sewing (it can be set in step of 100rpm)	400~3200	3000	
2.15	Sewing speed of 1 st Stitch (thread-catching) (It can be set in step of 100rpm)	400~1500	1200	
3.30	Sewing speed of 2 nd Stitch (thread-catching) (It can be set in step of 100rpm)	400~3200	2500	
4.30	Sewing speed of 3 rd Stitch (thread-catching) (It can be set in step of 100rpm)	400~3200	2700	
5.30	Sewing speed of 4 th Stitch (thread-catching) (It can be set in step of 100rpm)	400~3200	3000	
6.30	Sewing speed of 5 th Stitch (thread-catching) (It can be set in step of 100rpm)	400~3200	3200	
9.--	Changeover time of thread tension at thread-trimming	-6~4	4	
10. 4	Sewing speed of 1 st Stitch (no thread-catching) (It can be set in step of 100rpm)	400~1500	400	
11. 9	Sewing speed of 2 nd Stitch (no thread-catching) (It can be set in step of 100rpm)	400~3200	900	
12.27	Sewing speed of 3 rd Stitch (no thread-catching) (It can be set in step of 100rpm)	400~3200	2700	
13.30	Sewing speed of 4 th Stitch (no thread-catching) (It can be set in step of 100rpm)	400~3200	3000	
14.32	Sewing speed of 5 th Stitch (no thread-catching) (It can be set in step of 100rpm)	400~3200	3200	
16.--	Changeover timing of thread tension at the sewing start (no thread-catching)	-5~2	-5	
17. 0	Whether to change or indicate the XY scale rate and max speed limitation	0: changeable 1 : unchangeable	0	
18. 0	Action of Counter	0: Production Counter(Adding Method) 1 : Bottom Thread Counter(Subtracting Method)	0	





No.	Functions	Adjustment Range	Default Value	Remarks
25.1	Presser Division	0~1	1	0: Divide 1: Not divided;
26.70	Adjustment of presser height in section	50~90	70	
31.0	Use keyboard (Clear Key) to stop sewing machine	0: invalid 1: Reset Key	0	
32.1	Buzzer forbidden	0: no voice 1 : panel operation voice	1	
33.1	Set number of stitches that thread-catching releases	1~7	1	
34.--	Time deferrable in catching thread	-10~0	0	Speed down in direction “_”
35.1	Enable to forbid the control on catching upper thread	0: Normal 1: Forbidden	1	
36.--	Select the Feed time. When stitches are not well tightened, set the value in “-” direction.	-8~16	12	If it moves to one side excessively, the needle might be broken. Be careful at sewing the thick fabric.
37.1	Presser status at sewing end	0 : Depress pedal to lift presser 1: Presser goes up automatically	1	
39.0	Search origin at sewing end of each time (except the cyclic sewing)	0: Not search origin 1 : Search Origin	0	Refer to【 3.3 Recovery to Default Setting】
40.0	Search origin at cyclic sewing	0: Not Search origin 1 : Search origin after the finish of each pattern	0	

No.	Functions	Adjustment Range	Default Value	Remarks
42.0	Stop position of needle rod	0 : upper position 1 : highest position	0	Stop at highest point: Needle rod stops at the upper position and reverses.
46.0	Forbid thread-trimming	0: normal 1 : forbid thread-trimming	0	
49.16	Set winding speed	800~2000	1600	
201.- -	Whether to read the pattern data.	0: unable 1: able	Setting depends on model used.	Whether the pattern can be opened can be set respectively.
P- - -	Register pattern			
C- - -	Register the cyclic sewing			

14 Setting of service parameter

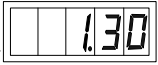
The Service Parameter is different from the ordinary parameter. Generally, these parameters are provided to the technicians for their debugging, and the users are forbidden to change them without directions from the professionals.

14-1. Activation & modification of service parameter

When the sewing LED is off, operator can press  to have system display , then the operator needs to press    together. After hearing the voice from buzzer, the operation can activate and modify the service parameters
The modification is same to that of the ordinary parameters.

14-2. Table of service parameters

No.	Definition	Adjustment Range	Initial Value	Remarks
21.--	Positions of standard pedal & pedal switch	50-200	70	If increasing the set value, user will need to depress presser harder.
22.--	Position of standard pedal & stroke switch of high/low section.	50-200	120	If increasing the set value, user will need to depress presser harder.
24.0	Single/ Double Pedal	0: Single 1: Double	0	
23.--	Position of standard pedal & start switch	50-200	185	If increasing the set value, user will need to depress presser harder.
27.--	Dropping speed of presser at depressing pedal	100-4000pps	4000	
28.--	Lifting speed of presser at depressing pedal	100-4000pps	1500	The excessive lifting will cause problems in operation.
29.--	Lifting speed of thread-trimming presser at sewing end	100-4000pps	3000	The excessive lifting will cause problems in operation.
38.--	Start sewing with switch when presser keeps still	0 or 1	0	0: Normal 1: Not lift presser
43.0	Selection of machine rotating number at thread-trimming	0: 400rpm 1: 800rpm	0	Rotation number at dividing thread with moving knife; the thread-trimming is performed after the machine ends
44.1	Selection on whether to feed cloth in the easy direction at thread-trimming	0: Not Feed 1: Feed Cloth	1	
45.--	Guide diameter of needle hole for feeding cloth at thread-trimming (Changing step can be set at 0.2mm.)	16~40	16	1.6mm~4.0mm
50.--	Thread-trimming Angle	0~9	5	
56.--	Limited range of motion in +X direction (Right)	-20-20mm	20	In the initial status, regardless shape of presser.
57.--	Limited range of motion in -X direction (Left)	-20-20mm	-20	In the initial status, regardless shape of presser.
58.--	Limited range of motion in +Y direction (Back)	-20-20mm	10	In the initial status, regardless shape of presser.
59.--	Limited range of motion in -Y direction (Front)	-20-10mm	-20	In the initial status, regardless shape of presser.

No.	Definition	Adjustment Range	Initial Value	Remarks
62.0	Pattern Update	0: Normal Mode 1:Pattern update mode	0	For updating the pattern, please refer to 【 5 Updating pattern via U disk】
67.--	Default parameter transfer	0 or 1	1	For this parameter, please refer to【 3.3 Recovery to Default Setting】
68.--	Main-shaft stop compensation	-10+10	0	
90.--	Preset value for bottom thread counter	0~9999	0	
91.--	Current value for production (bottom thread) counter	0~9999	0	
121	Counter Lock	0,1,2 or 3, Need U-KEY open it	0	0 :Can Clear and Plus/Minus ; 1 :Can Clear Only ; 2 :Can Plus/Minus Only; 3 :Can not Clear and Plus/Minus
124.3	Stepping Open/Close Loop Shift	0,1,2or 3	3	0:DSP1Close DSP2Close 1:DSP1Open DSP2Open 2:DSP1Close DSP2Open 3:DSP1Open DSP2Open
125	Stepping Software Version	Press +/- to shift DSP		1-XXX for DSP1, 2-XXX for DSP2
133	Thread-stirring Delay Adjustment	0~12	0	× 10ms adjustable
35.1	Catch up line or not	0:Catch 1:Not	1	
138.1	Thread Tension Control(Need Restart)	0 or 1	1	0: Thread-catching Method 1:Thread-standing Method
150.0	Invalidity of head tilt safety switch	0 or 1	0	0: Normal 1: The safe shape of head tilt is invalid.
163	Valve Middle Presser Action Delay	0-200	20	0 Deactivate Middle Presser ; Other Number: Middle Presser Action Delay ×10ms
241.0	Functional selections		0	0: Bar-tacking 2: Fishing net 5: 60× 40 7: Button sewing
U-KEY	Counter secret code			
UKCLR	Counter secret code reset			
K-KEY	Top speed secret code			
KKCLR	Top speed secret code reset			



The parameters above are only for the repair technicians, and ordinary users are forbidden to change those parameter

14-3.Recovery to default setting

If the user changes some parameters by mistake, which are properly set at delivery, he will use the function of “Recovery to Default Setting” to restore the system.



At recovering the default settings, the entire parameters that are set by user before will be covered. Therefore, please take caution in using this function. For anything unknown, please contact the technicians of the manufacturer, and operate the machine with the instruction from the professionals

The following is the specific operation step :

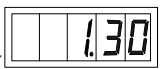
1. When the Sewing LED is off, operator can press to have system display , and then the operator needs to press together. Following the voice from buzzer, the modification of service parameters is started.
2. By using the & , the operator can select the parameter No.67:

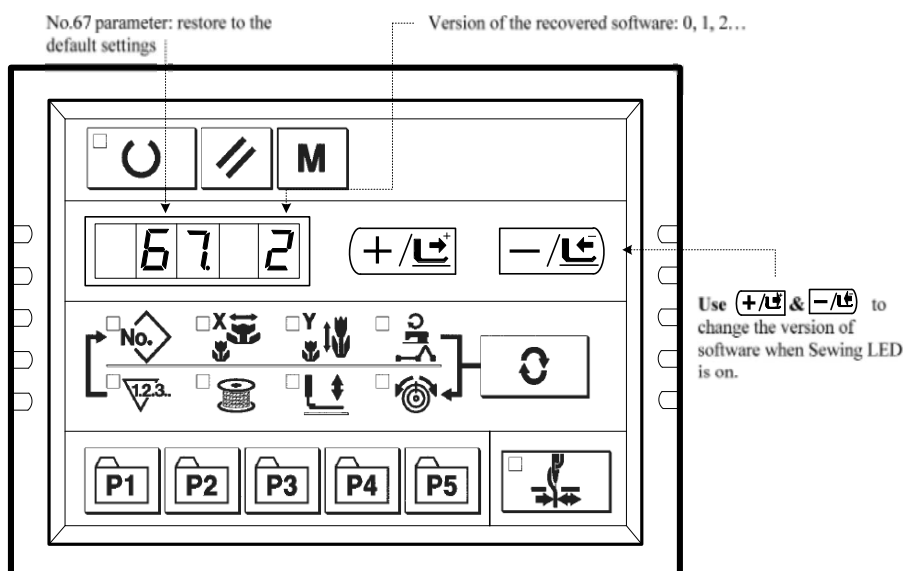

3. Press to turn the sewing LED, then select the needed software version number by using & :

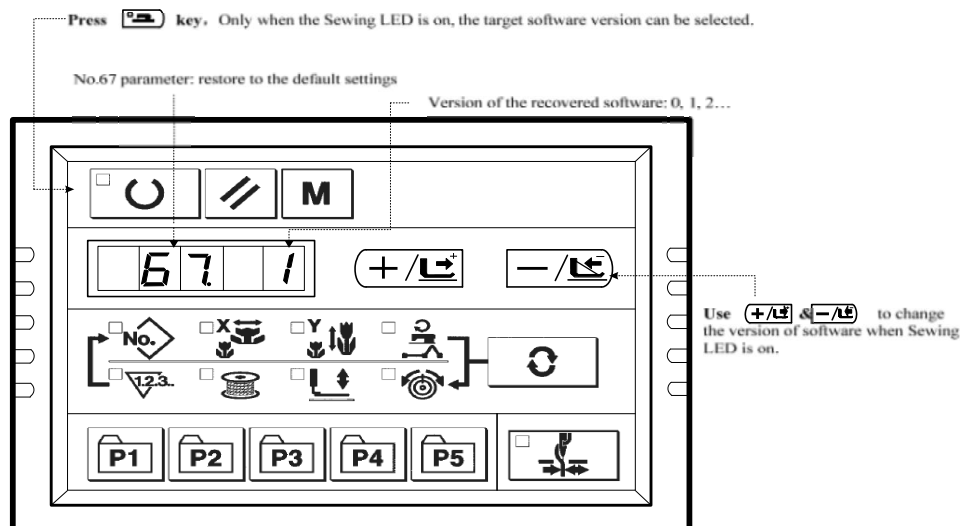

4. For an example, if the existing version is 2, operator can restore it to 0 or 1 (smaller than the current version number in all). And then press to confirm the restored version number and turn off the Sewing LED;
5. Press to quit the setting mode of service parameters. Then the system will return to the normal sewing mode;
6. And then, turn off the power and repower the machine after about one minute. At the moment, “EEP—” will be displayed on the operation panel. After 20 seconds, the operation panel will become to display normally (attention: it is a normal phenomenon because the system needs some time to perform the recovery of the default software).
7. After the recovery, the system will set the current software version as the highest version. For example, there are 2 default versions, Version 1 & Version 0; in that case the version after the recovery will be defined at 2 automatically.

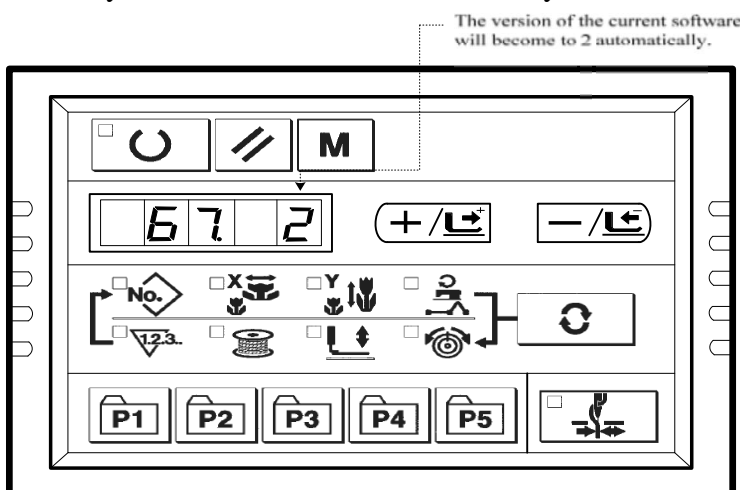

Attention: During the process of repowering the machine, if the power is off when the system is recovering, the recovery will be failed and the system will return to the software status before the recovery.

[6] MAINTENANCE

1. Adjusting the height of the needle bar

 **WARNING :** Turn OFF the power before starting the work so as to prevent accidents caused by abrupt start of the sewing machine.

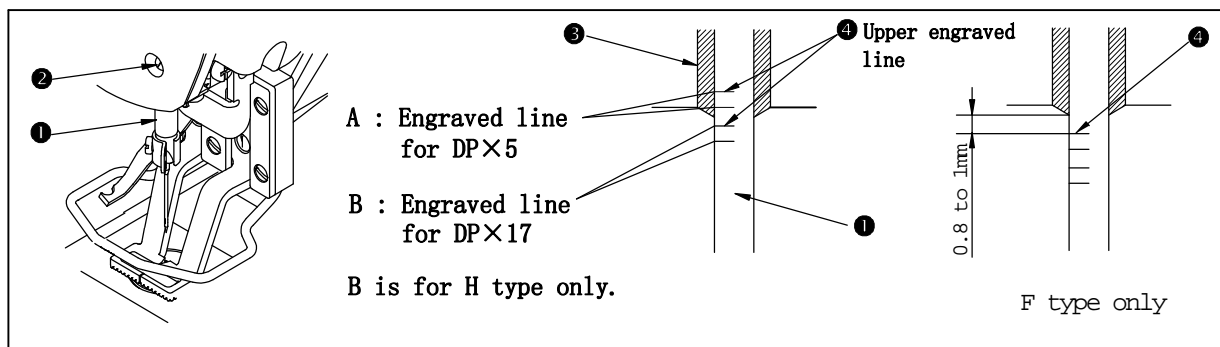

Bring needle bar ① to the lowest position of its stroke. Loosen needle bar connection screw ② and adjust so that upper marker line ④ engraved on the needle bar aligns with the bottom end of needle bar bushing, lower ③. For F type only, adjust the needle bar to the position where it is lowered by 0.8 mm to 1 mm from the center of upper marker line ④ engraved on the needle bar.

 After the adjustment, make sure that there is no uneven torque. When stitch skipping occurs in accordance with the sewing conditions, adjust the height of the needle bar so as to lower it by 0.5 to 1 mm from the needle bar engraved line ④.

2. Adjusting the needle-to-shuttle relation

 **WARNING :** Turn OFF the power before starting the work so as to prevent accidents caused by abrupt start of the sewing machine.

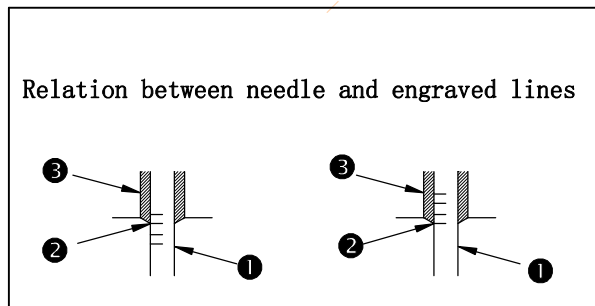

(1). Turn the hand wheel by hand. When needle bar (1) has gone up, adjust so that lower marker line (2) engraved on the needle bar aligns with the bottom end of the needle bar bushing (3), lower.

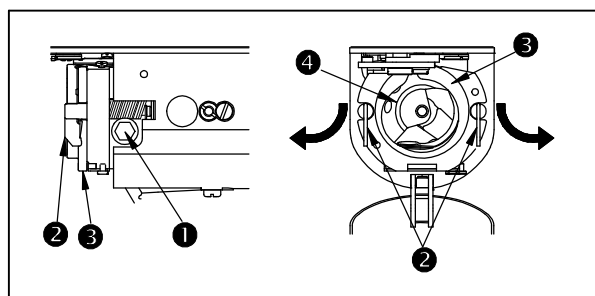

(2). Loosen setscrew (1) in the driver. Open inner hook pressers (2) to the right and left, and remove inner hook presser (3).

Caution At this time, be careful not to let inner hook (4) come off and fall.

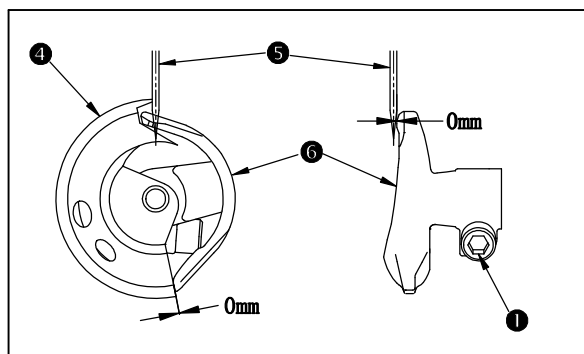

(3). Adjust so that the blade point of inner hook (4) aligns with the center of needle (5), and that a clearance of 0 mm is provided between the front end of the driver and the needle as the front end face of driver (6) receives the needle to prevent the needle from being bent. Then tighten setscrew (1) of

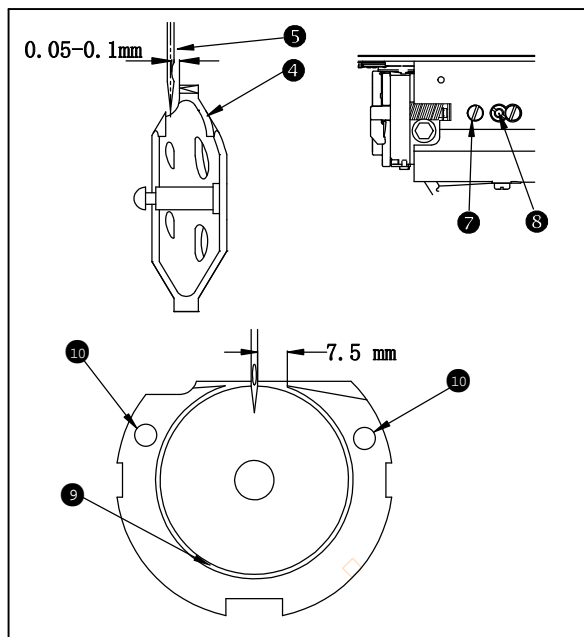

(4). Loosen setscrew (7) of the shuttle, and adjust the longitudinal position of the shuttle. To do this adjustment, turn shuttle race adjusting shaft (8) clockwise or counterclockwise to provide a 0.05 to 0.1 mm clearance between needle (5) and the blade point of inner hook (4).

(5). After adjusting the longitudinal position of the shuttle, further adjust to provide a 7.5 mm clearance between the needle and the shuttle by adjusting the rotating direction. Then tighten setscrew (7) of the shuttle.

Caution Apply a small amount of oil to race section (9) and oil wick (10), and use the sewing machine after an extended period of disuse or cleaning the periphery of hook portion.

3. Adjusting the lift of the work clamp foot



WARNING :

Turn OFF the power before starting the work so as to prevent accidents cause by abrupt start of the sewing machine.

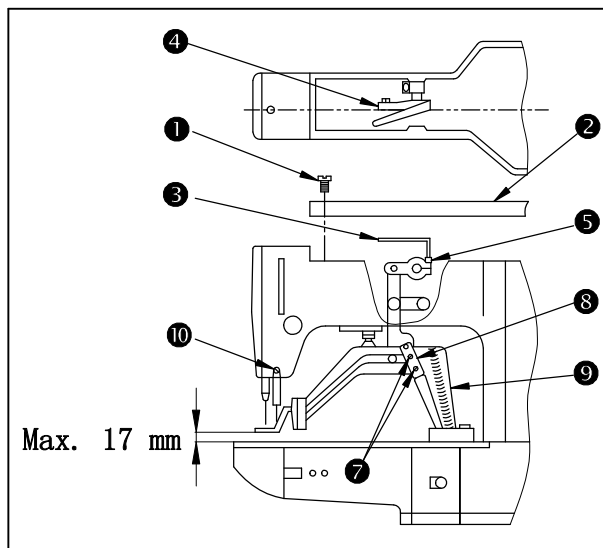

- (1) . With the machine in stop mode, remove six set screws ① of the top cover, and take off top cover ②.
- (2) . Apply L-shaped wrench ③ to socket bolt ⑤ of clamp ④ , and loosen the socket bolt.
- (3) . Push down L-shaped wrench ③ to increase the lift of the work clamp foot, or pull it up to decrease the lift.
- (4) . After the adjustment, securely tighten socket bolt ⑤.
- (5) . If the right and left work clamp feet are not leveled, loosen fixing screw ⑦ and adjust the position of the work clamp foot lever support plate ⑧ to level them.



At this time, be careful not to cause work clamp foot lever support plate ⑧ to interfere with feed bracket ⑨ .

If the work clamp foot lever support plate interferes with the wiper, readjust the height of the wiper using setscrew ⑩ in the wiper installing base.

4. The moving knife and counter knife



WARNING :

Turn OFF the power before starting the work so as to prevent accidents cause by abrupt start of the sewing machine.

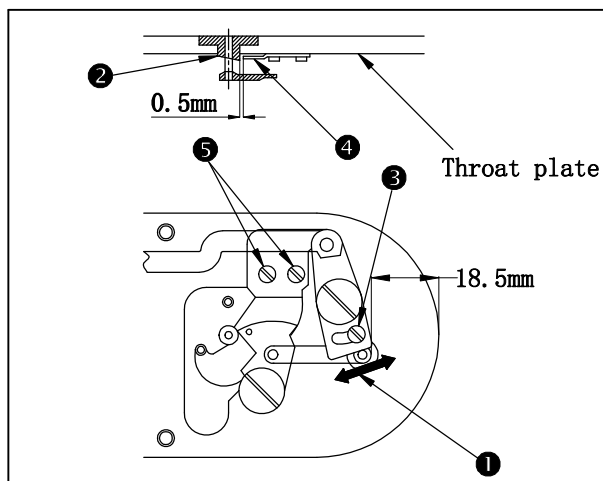

- (1). Loosen adjusting screw ③ so that a clearance of 18.5 mm is provided between the front end of the throat plate and the top end of thread trimmer lever, small ① . To adjust, move the moving knife in the direction of arrow.
- (2). Loosen setscrew ⑤ so that a clearance of 0.5 mm is provided between needle hole guide ② and counter knife ④ . To adjust, move the counter knife.

5. Needle thread clamp device



WARNING : Turn OFF the power before starting the work so as to prevent accidents cause by abrupt start of the sewing machine.

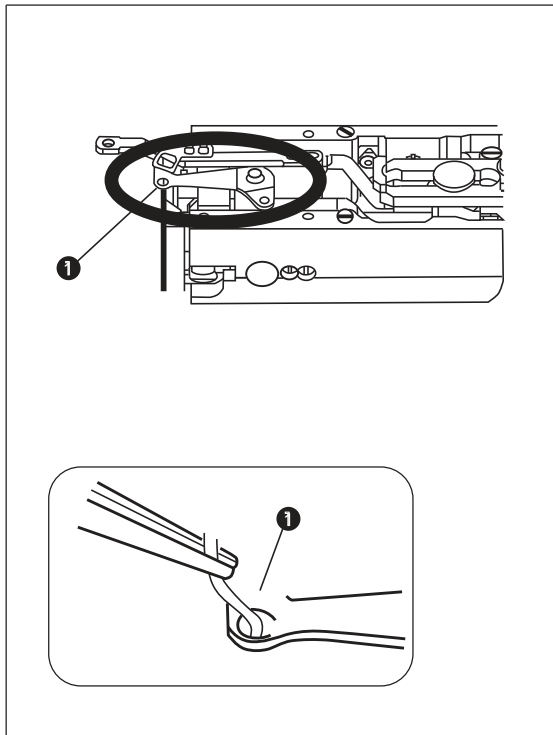

(1) .When thread is caught at top end ① of the thread clamp, thread clamp becomes incomplete and sewing trouble at the sewing start will be caused.

Remove it with tweezers or the like.

(2) . When removing thread waste or thread dust collected on the thread clamp device, remove it after removing the throat plate.

6. Adjustment of the wiper



WARNING : Turn OFF the power before starting the work so as to prevent accidents cause by abrupt start of the sewing machine.

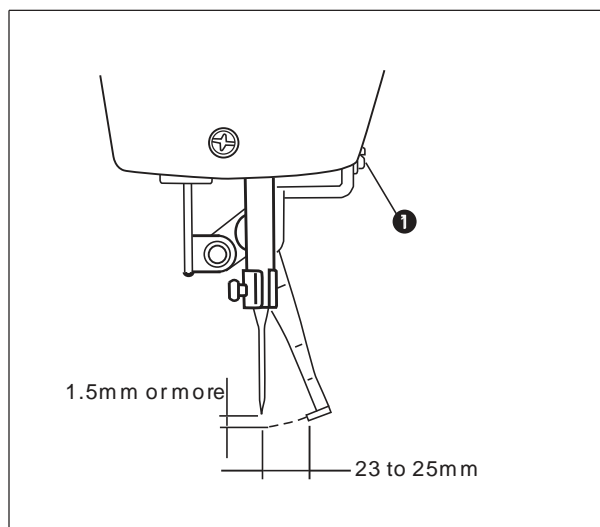

Loosen screw ①to adjust so that a clearance of 1.5 mm or more is provided between the wiper and the needle.

At this time, the standard of the distance between the wiper and the needle is 23 to 25 mm. By adjusting the distance wide, the work clamp foot can prevent stepping on needle thread when it comes down.

Especially when the thin needle is used, adjust the distance wide to such an extent of 23 mm.

✖The position of the needle is when the sewing machine has stopped after the sewing finished.

7. Draining waste oil

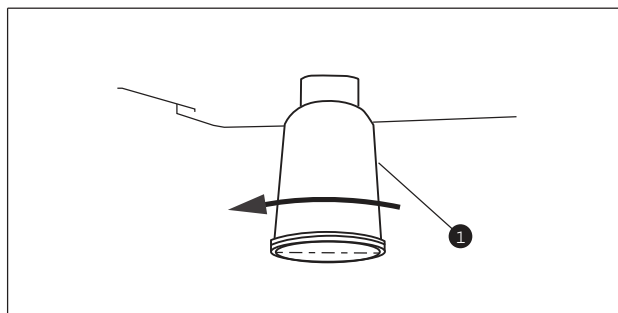

When polyethylene oiler ① becomes filled with oil, remove polyethylene oiler ① and drain the oil.

8. Amount of oil supplied to the hook

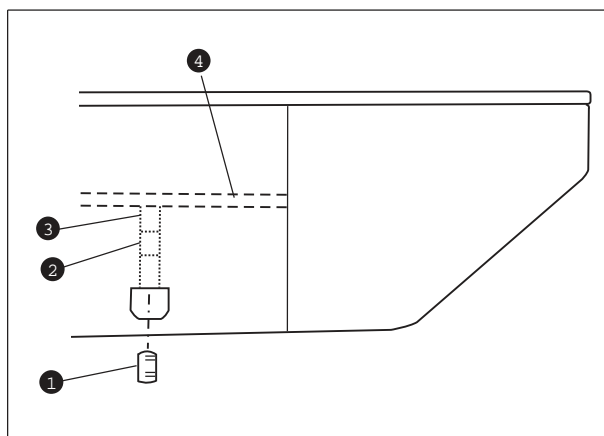

- 1) Loosen setscrew ① and remove setscrew ①.
- 2) When screwing in adjustment screw ②, the amount of oil of oil pipe, left ④ can be reduced.
- 3) After the adjustment, screw in setscrew ① and fix it.



1. The state of standard delivery is the position where ③ is lightly screwed in and returned by 4 turns.
2. When reducing the amount of oil, do not screw in the screw at once. Observe the state for approximately half a day at the position where ③ is screwed in and returned by 2 turns. If reducing is excessive, worn-out of the hook will result.

9. Replenishing the designated places with grease

When the sewing machine has been used for a certain number of times of sewing, error code No. E220 is displayed on the operation panel at the time of turning ON the power. This display informs the operator of the time of replenishing the designated places with oil. Be sure to replenish the places with the oil below. Then call the memory switch No. 245 and set it to "0" with the RESET key. Even after the display of the error No. E220, when the RESET key is pressed, the error is released, and the sewing machine can be continuously used. Afterwards, however, the error No. E220 is displayed every time the power is turned ON.

In addition, when the sewing machine is used further for a certain period of time after the display of error No. E220, the error No. E221 is displayed and the sewing machine fails to operate since the error cannot be released even when the RESET key is pressed.

When the error No. E221 is displayed, be sure to replenish the designated places below with oil. Then start up the memory switch and set No. 245 to "0" with the RESET key.



After replenishing the places with oil, the error No. E220 or No. E221 is displayed again unless the memory switch No. 245 is changed to "0".

**WARNING :**

Turn OFF the power before starting the work so as to prevent accidents cause by abrupt start of the sewing machine.

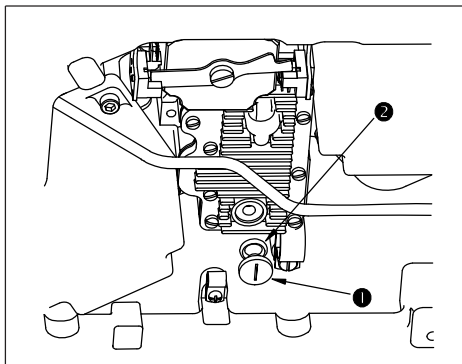
(1) . Outflow the residual oil in gearbox

- 1) Tilt the machine, remove the screws (1) and seal (2).
- 2) put back sewing machine, outflow the residual oil in the gearbox.
- 3) tilt the machine again, put back the seals (2) and screws (1), then put sewing machine back to the position.

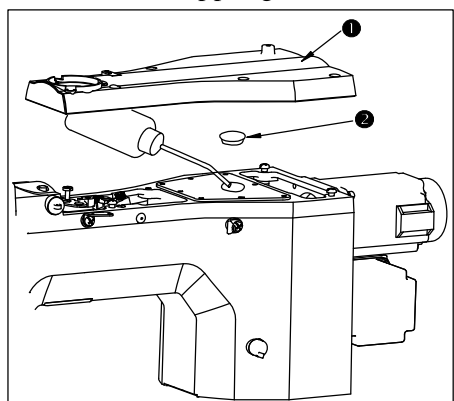









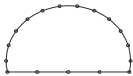

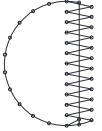



(2) . Lubricate the upper gearbox





- 1) Open the cover (1), and the rubber plug (2);
- 2) Add 10# white oil 110-130ml to the gear box, then close the rubber plug (2).



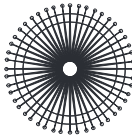
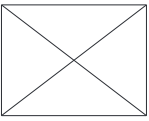
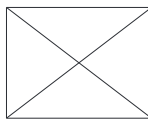
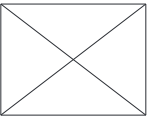
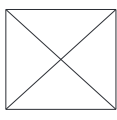

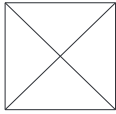
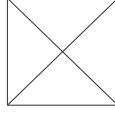
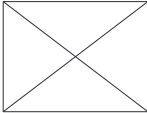
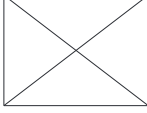
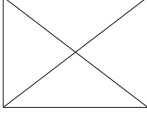
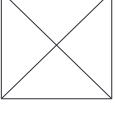
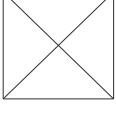
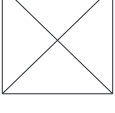
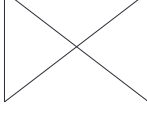

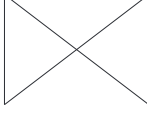
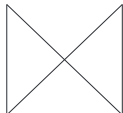
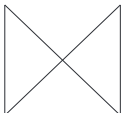
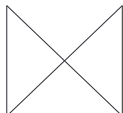
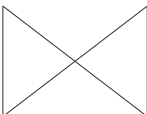
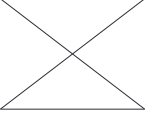
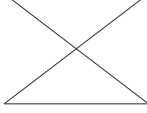
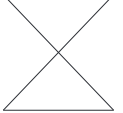
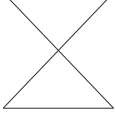
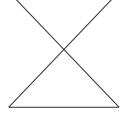

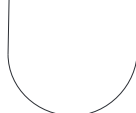

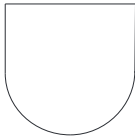
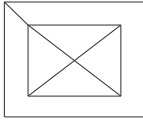
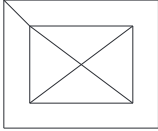
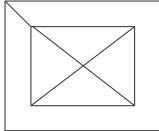
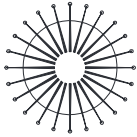
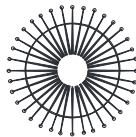
[7] Table of the standard patterns and the standard patterns

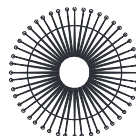
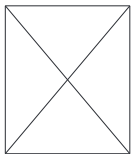
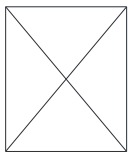
1. List of standard figure

NO.	Sewing Pattern	Stitch number	Size (mm)	NO.	Sewing Pattern	Stitch number	Size (mm)
1		42	16×2	2		42	10×2
3		42	16×2.5	4		42	24×3
5		28	10×2	6		28	16×2.5
7		36	10×2	8		36	16×2.5
9		56	24×3	10		64	24×3
11		21	6×2.5	12		28	6×2.5
13		36	6×2.5	14		15	8×2
15		21	8×2.2	16		28	8×2
17		19	10×1	18		39	10×1
19		27	25×1	20		35	25×1
21		39	25×1	22		43	35×1
23		28	4×20	24		36	4×20
25		42	4×20	26		56	4×20
27		18	1×20	28		21	1×10
29		21	1×20	30		28	1×20
31		52	10×7	32		63	12×7

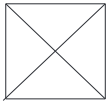
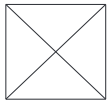
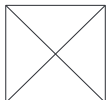
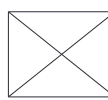
33		24	10×6	34		31	12×6
35		48	7×10	36		48	7×10
37		90	24×3	38		28	8×2
39		28	12×12	40		48	12×12
41		29	2.5×20	42		39	2.5×25
43		45	2.5×25	44		58	2.5×4.4
45		76	2.5×4.4	46		42	2.5×4.4
47		91	8×8	48		99	8×8
49		148	8×8	50		164	8×8
51		100	40×30	52		78	40×30
53		70	40×30	54		90	30×30

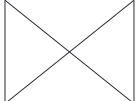
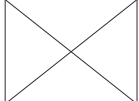
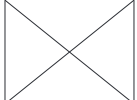
55		70	30×30	56		54	30×30
57		53	40×30	58		40	40×30
59		31	40×30	60		45	30×30
61		36	30×30	62		27	30×30
63		57	40×30	64		45	40×30
65		35	40×30	66		55	30×30
67		42	30×30	68		33	30×30
69		65	40×30	70		49	40×30
71		39	40×30	72		55	30×30
73		42	30×30	74		33	30×30
75		43	30×30	76		33	30×29.9

77		26	30×29.8	78		93	30×25
79		72	30×25	80		54	30×25
81		109	8×8	82		125	8×8
83		132	8×8	84		141	8×8
85		69	20×24.1	86		52	20×24.1
87		101	40×5	88		109	40×5
89		97	5×30	90		107	5×30
91		56	20×20	92		48	20×20
93		38	20×20	94		62	25×20
95		50	25×20	96		40	25×20
97		36	25×20	98		28	25×20
99		24	25×20	100		76	30×25

2. Table of the work clamp foot

	1	2	3	4	5
Work clamp foot	Left: 10011508 Right: 10011505			10011687、10011691	10011758、10011759
Feed plate	10011565	10012300	10012279	10011751	10011755
	With knurl	Without knurl	Without knurl	With knurl	With knurl
Sewing specification	S	F	F	H	M
Finer guard	10011556(S、M、F)、10011695(H)				
Remarks	Standard accessory for S type machine head.	Supplied with F type machine head. (Depends on the destination)		Optional	Standard accessory for M (knit goods) type machine head.

	6	7	8	9	10	11
Work clamp foot	10012349(L) 10012342(R)		10012339(L) 10012346(R)	10012341(L) 10012348(R)		10026244(L) 10026245(R)
Feed plate	10012277	10012302	10012286	10012296	10012301	10026246
	With knurl	With knurl	With knurl	Without knurl	Without knurl	Without knurl
Sewing specification	S	H/W	S	F	F	F
Finer guard	10011556(S、M、F)、10011695(H、W)					
Remarks	Optional	Standard accessory for H type(heavy-weight material) machine head.	Optional	Accessory part for F(foundation)type.(Depends on the destination)		Optional

	12	13	14	15	16
	10026247(L) 10026248(R)	10026250(L) 10026251(R)	10012344(L) 10012345(R)	10026253(L) 10026254(R)	10026256(L) 10026257(R)
Work clamp foot					
	10026249	10026252	10012338	10026255	10026258
	Without knurl	Without knurl	Without knurl	Without knurl	Without knurl
Feed plate					
Sewing specification	F	S	S	S	S
Finger guard	10011556				
Remarks	Optional	Optional	Optional	Optional	Optional

✱ Install a finger suitable for each work clamp foot when replacing the work clamp foot.

[8] Table of the optional parts

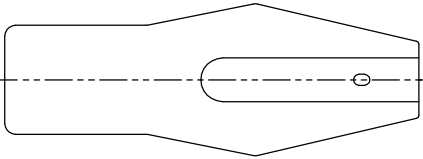
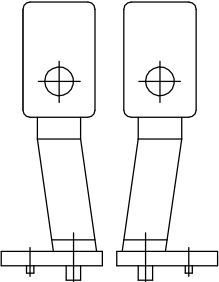
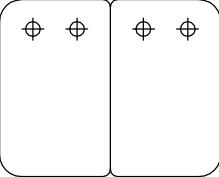
Name of Parts	Type	Part No.	Remarks
 <p style="text-align: center;">t=1.2</p>	Without knurl / processed Sewing area lengthwise 20 X crosswise 40	10026226	
	With knurl / processed Sewing area lengthwise 20 X crosswise 40	10012303	
	Without knurl / stainless steel Sewing area lengthwise 20 X crosswise 40	10026227	t=0.5
	Without knurl / processed Sewing area lengthwise 30 X crosswise 40	10026228	
	Without knurl / without processing Sewing area lengthwise 30 X crosswise 40	10026237	
	Without knurl / stainless steel Sewing area lengthwise 30 X crosswise 40	10026238	t=0.5
	With knurl / processed Sewing area lengthwise 30 X crosswise 40	10014401	
	With knurl / without processing Sewing area lengthwise 30 X crosswise 40	10026239	
<p>Work clamp foot face plate (asm.)</p> 		10026229 10026230	Face plate for presser blank
<p>Presser blank</p>  <p style="text-align: center;">t=3.2</p>	With knurl / Processed (right) Sewing area lengthwise 20 X crosswise 40	10026232	
	With knurl / Processed (Left) Sewing area lengthwise 20 X crosswise 40	10026231	
	With knurl / Processed (right) Sewing area lengthwise 30 X crosswise 40	10026241	
	With knurl / Processed (Left) Sewing area lengthwise 30 X crosswise 40	10026240	
	With knurl / without processing (right) Sewing area lengthwise 30 X crosswise 40	10026243	
	With knurl / without processing (Left) Sewing area lengthwise 30 X crosswise 40	10026242	

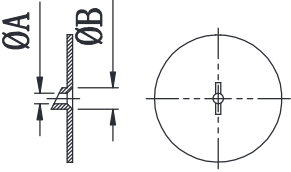
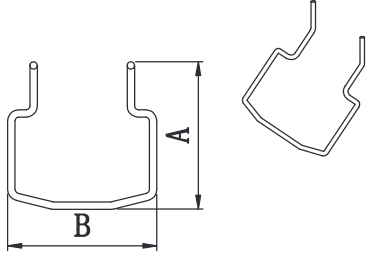
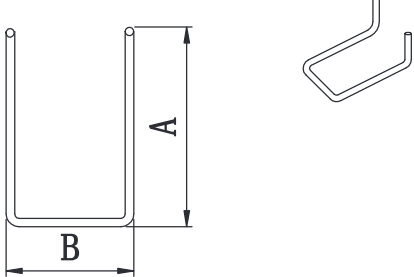
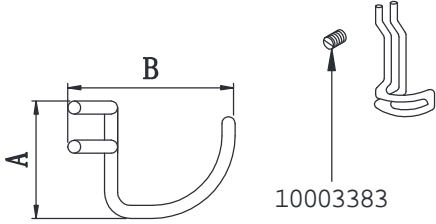
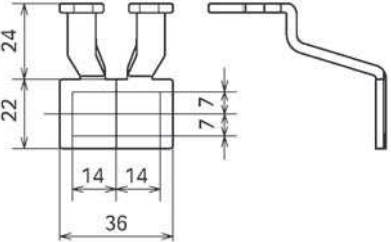
<p>Needle hole guide</p> 	<p>A=1.6 B=2.6 With relief slit</p>	<p>10004646</p>	<p>Standard type</p>
	<p>A=1.6 B=2.0 Without relief slit</p>	<p>10011757</p>	<p>F and M types</p>
	<p>A=2.3 B=4.0 Without relief slit</p>	<p>10004727</p>	<p>H and W types</p>
	<p>A=2.7 B=3.7 Without relief slit</p>		<p>For extra heavyweight material</p>
<p>Finger guard(1)</p> 	<p>A=56.5 B=64</p>	<p>10011556</p>	
	<p>A=59 B=74</p>	<p>10011695</p>	<p>For large size bar tacking</p>
<p>Finger guard (2)</p> 	<p>A=66.5 B=43</p>	<p>10014408</p>	<p>For lengthwise bar tacking</p>
<p>Finger guard (3)</p> 	<p>A=21.5 B=35.5</p>	<p>10026235</p>	<p>For specially ordered work clamp</p>
<p>Work clamp foot blan</p> 	<p>With knurl / processed (right)</p>	<p>10026234</p>	
	<p>With knurl / processed (left)</p>	<p>10026233</p>	

II. EXPLANATION OF THE 1903D, COMPUTER-CONTROLLED HIGHSPEED LOCKSTITCH BUTTON SEWING MACHINE

[1] Specifications

Different specifications from those of the 1900DSS only are described.

- 1) Sewing speed Max. 2,700rpm
- 2) Needle DPx17 #14
- 3) Lifting method of the work clamp foot..... Stepping motor
- 4) Lift of the work clamp foot Max. 13mm
- 5) Number of standard patterns50 patterns
- 6) Wiper method Interlocked with work clamp foot lifter driven by stepping motor

 The needle thread clamp device is set to prohibition (state of standard delivery) with memory switch No. 35.

[2] Installation of the sewing machine and preparation of the operation

 **WARNING :** Be sure to perform the work with two persons or more when moving the sewing machine

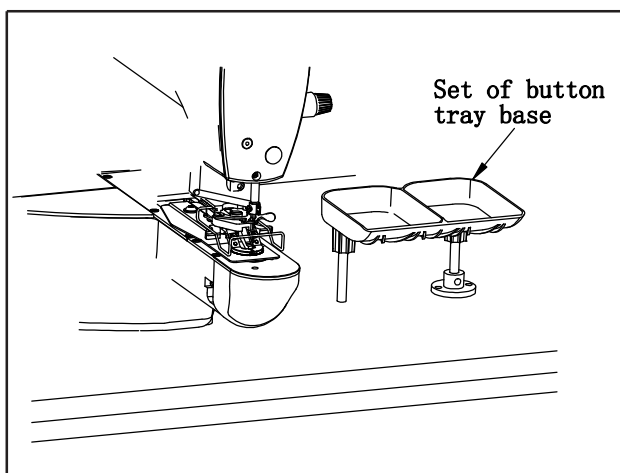

- (1). Installation of the sewing machine head and the control box is same as that of the 1900DSS. Refer to the instruction manual for the 1900DSS.
- (2). Install a set of the button tray base to a convenient place for the work as the set is included in the accessories

 Make sure before operation that the needle does not strike against the button hole .

[3] Needle and thread

Needle	Needle thread	Bobbin thread
DPx17 #14	#60	#80
	#60	#60
	#50	#60
	#40	#60



Needle and thread will vary in accordance with the sewing conditions. when using the needle and the thread, select them referring to the left table. Cotton thread and polyester spun thread are recommended.

[4] Various sewing modes

1. List of sewing patterns

Number of threads and standard sewing size of X and Y are as shown in the following list.

No	Sewing pattern	Thread number	Standard swing length X(mm)	Standard sewing length (mm)	No	Sewing pattern	Thread number	Standard sewing length X(mm)	Standard sewing length Y(mm)
1- 34		6-6	3.4	3.4	18- 44		6	3.4	0
2- 35		8-8			19- 45		8		
3		10-10			20		10		
4		12-12			21		12		
5- 36		6-6			22		16		
6- 37		8-8			23- 46		6	0	3.4
7		10-10			24		10		
8		12-12			25		12		
9- 38		6-6			26- 47		6-6	3.4	3.4
10- 39		8-8			27		10-10		
11		10-10			28- 48		6-6		
12- 40		6-6			29		10-10		
13- 41		8-8			30- 49		5-5-5		
14		10-10			31		8-8-8		
15- 42		6-6			32- 50		5-5-5		

No	Sewing pattern	Thread number	Standard swing length X(mm)	Standard sewing length (mm)	No	Sewing pattern	Thread number	Standard sewing length X(mm)	Standard sewing length Y(mm)
16- 43		8-8			33		8-8-8		
17		10-10							

2. Selection of the sewing pattern and the sewing width.

(1). Selection of the sewing pattern is the same as that of the 1900D.

(2). When the distance between holes of the button used does not fit the standard sewing width of the sewing pattern No., adjust the sewing width by enlarging/reducing the sewing width.

The way of enlarging/reducing is the same as that of the 1900D. Refer to the table given below for the scale for enlargement/reduction in terms of the sewing width.

(3). After changing the sewing pattern No. and the sewing width , make sure of the needle entry point. As for the way of confirmation, refer to the confirmation of the shape of sewing pattern in the instruction manual for the 1900D.



Table of XY scale in terms of the sewing width

X·Y (m m)	2.4	2.6	2.8	3.0	3.2	3.4	3.6	4.0	4.3	4.5	4.7	5.2	5.6	6.0	6.2	6.4
%	71	76	82	88	94	100	106	118	126	132	138	153	165	176	182	188

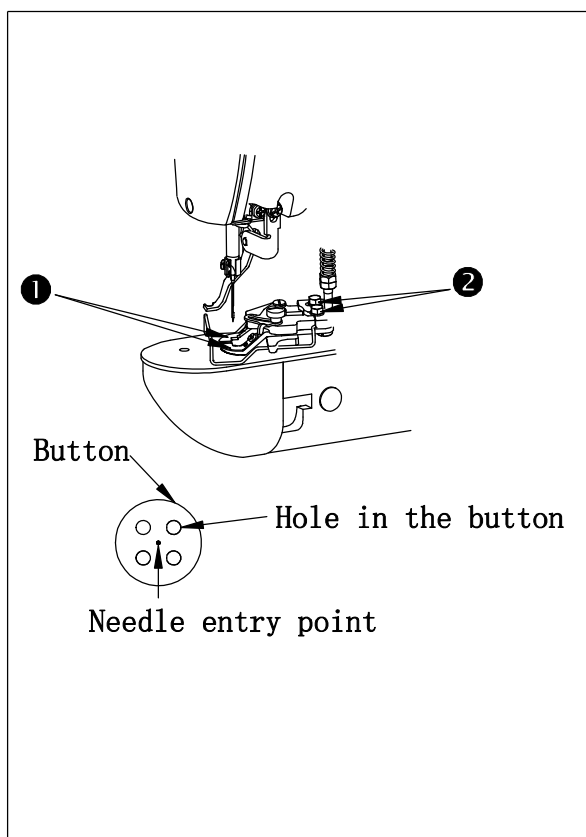
[[5] Position of the button clamp jaw lever



(1). Press  key in the state that the swing LED goes off using the operation panel.

(2). Press  key.  

(3). Press  key. The button clamp unit goes to the origin position and goes up.

(4). Place a button in button clamp jaw levers ①.

(5). Depress the pedal to the first step and detach your foot from the pedal when the button clamp unit comes down.

(6). Turn the hand pulley and check that the center of the needle enters the center of the button.

(7). If the center of the needle is not located in the center of the button, loosen screws ② in the button clamp jaw lever base to adjust so that the center of the needle enters the center of the button.

(8). When depressing the pedal to the second step at step 5), the button clamp unit moves again to the origin position. In addition, when the button clamp unit comes down, depress the pedal to the first step and detach the foot from the pedal. Then the button clamp unit goes up.

(9). After the adjustment, perform the confirmation of the pattern shape and make sure that the needle surely has entered the button hole.

WARNING: When change of the shape of button , change of the sewing pattern or





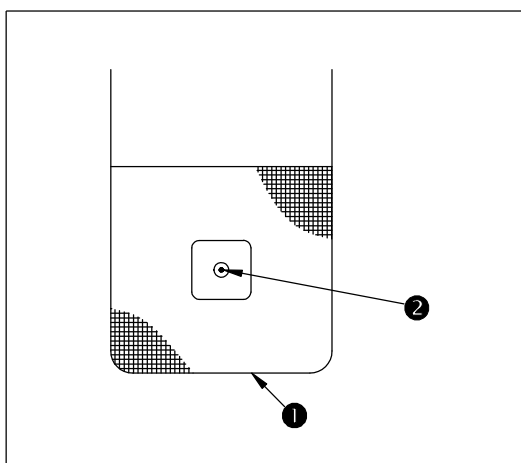

enlargement/reduction of the sewing width is performed, make sure the needle entry point. If the needle extends outside the button hole or the sewing pattern extends outside the button clamp unit, the needle interferes with the button hole or the button clamp unit, resulting in the danger of the needle breakage or the like.

[[6] Adjusting the feed plate

WARNING: When change of the shape of the button, change of the sewing pattern or enlargement/reduction of the sewing width is performed, make sure of the shape of the sewing pattern. If the feed plate interferes with the needle hole guide, it will result in the danger of the needle breakage or the like. Also, if the pedal is depressed during the adjustment, the button clamp unit will go up or come down. So, be careful.



- (1) .in the state that the LED light off, press the key  operation panel, choose winder  state, light on.
- (2) .press  key, the button clamp unit goes to the original position and goes down.
- (3) . adjust the feed plate ①, so the needle hole guide ② comes to the center of the recessed part of feed plate ①H.
- (4) . press  key, button clamp goes up, start sewing.

[[7] Adjusting the button clamp jaw lever



WARNING : Turn OFF the power before starting the work so as to prevent accidents cause by abrupt start of the sewing machine.

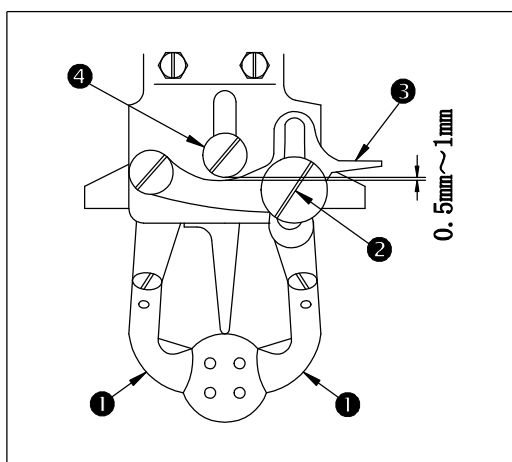

Bring the machine to its stop-motion state. Then lift button clamp ①. Loosen screw ② in the button clamp jaw lever and adjust so that a clearance of 0.5 to 1mm is provided between button clamp jaw lever ③ and hinge screw ④ when placing a button in between button clamps ①. Then tighten screw ② in the button clamp jaw lever.

[8] Adjusting the lifting amount of the button clamp



WARNING : Turn OFF the power before starting the work so as to prevent accidents cause by abrupt start of the sewing machine.

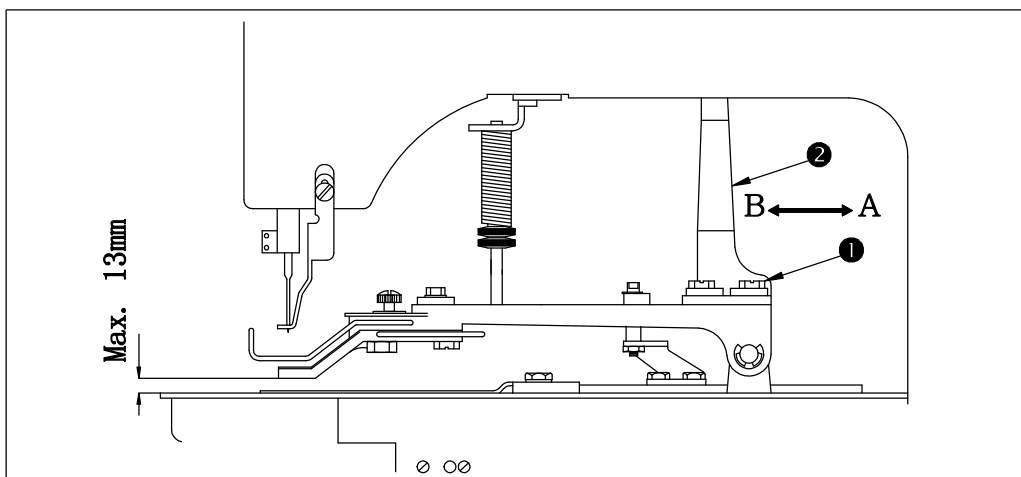

Loosen two setscrews ①, and move moving plate ② back and forth in the direction of arrow to adjust. The lifting amount of the button clamp will be decreased when moving plate ② is moved in the direction "A", and be increased when it is moved in the direction of "B". After the adjustment, securely tighten setscrews ①.

[9] Adjustment of the pressure of the work clamp unit



WARNING : Turn OFF the power before starting the work so as to prevent accidents cause by abrupt start of the sewing machine.

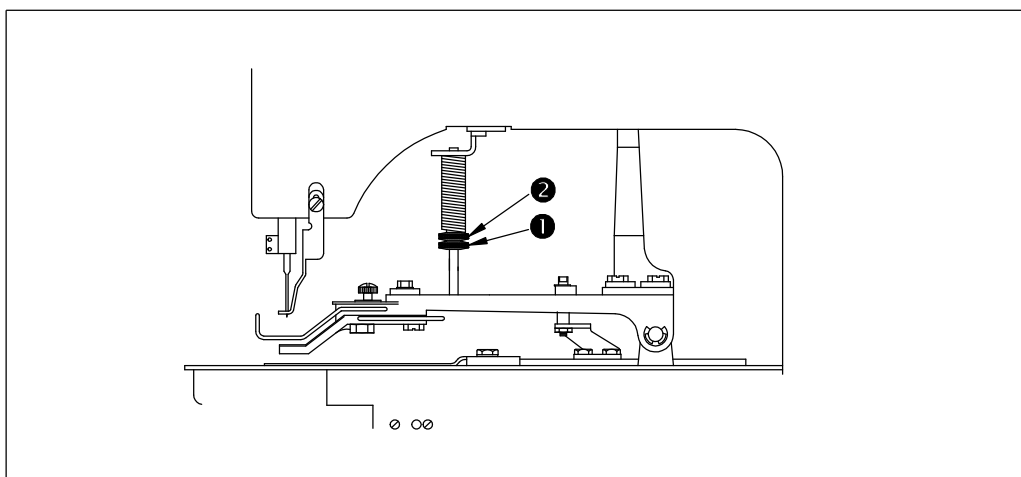

The pressure of the work clamp unit should be minimized as long as the material does not warp during sewing. Loosen adjusting screw ① and turn adjusting screw ② to obtain the aforementioned pressure.

[[10]] Adjustment of the wiper spring



WARNING : Turn OFF the power before starting the work so as to prevent accidents cause by abrupt start of the sewing machine.

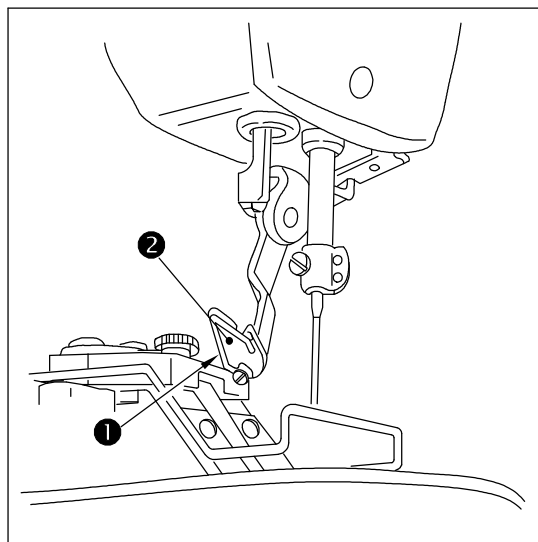

Wiper spring① retains the needle thread after thread trimming in between wiper② and the wiper spring. Correct properly the tension after wiper spring ① so that the tension at that time becomes 20 to 30 g(a little higher tension than that of the bobbin thread coming out of the bobbin case.



If the retaining of the needle thread is excessive, the thread may protrude from the upper side of the button.

[[11]] Each model of 1903D sewing scope

Model		1903D-301		
Button size classification		For medium-sized buttons		
Outside diameter of applicable buttons (mm)		Ø8~Ø22		
Sewing size (mm)	0~3.5	0 to 3.5		
	0~3.5	0 to 3.5		
Button clamp jaw lever	2.2 (2.7)		2.2 (2.7)	
	Part NO.	Right	10011523	
		Left	10011538	
Needle hole guide		10011825		
Feed plate		10011819		

III. List of error information

Display					Error Name	Content of Error	Solution
E				7	Machine Lock Error	The main-shaft of sewing machine can't rotate due to some problem.	Turn off power and release the trouble
E			1	0	Pattern NO. Error	The prepared pattern number is not registered in ROM or it is set at unreadable. The pattern is 0.	Press RESET switch to confirm the pattern NO. Confirm the content in memory switch No.201.
E			3	0	Needle Rod Up Position Error	The needle rod is not at UP position.	Turn the hand pulley to return the needle rod to its UP position.
E			4	0	Sewing Area Over	The sewing area is over the limit.	Press RESET switch to confirm the X/Y scale rate
E			4	3	Enlargement Error	The sewing stitch is below 10mm.	Press RESET switch and confirm the pattern and X/Y scale rate.
E			4	5	Pattern Data Error	The pattern data cannot be adopted.	Power off and check the data ROM
E			5	0	Pause	Press the RESET switch while sewing machine is running. The machine pauses.	Restart or return-to-origin after pressing RESET switch for thread-trimming
E		2	2	0	Controller Abnormal	The communication with executive device is abnormal.	Turn off the power and repower the machine after a while.
E		3	0	2	Head Tilt Error	Head tilt detection switch is turned ON.	The sewing machine cannot be operated with the head tilted. Return the sewing machine head to its proper position
E		3	0	3	Connection to Main-shaft Fail	Can't detection the highest point of the sewing machine	Turn off the power, and check the connection of the X5 plug.
E		3	0	5	Thread Trimmer Position Error	Knife is not at proper position.	Turn off the power and check the CZ024 at the head signal circuit board.
E		3	0	6	Thread-catching position error	The thread-catching device is at wrong position.	Turn off the power and check the CZ026 at the head signal circuit board.
E		3	0	7	Thread-trimming Motor Position Error	The thread-trimming motor is not at the right position.	Check the thread-trimming device and thread-trimming motor to make sure it has no blockage.
E		6	8	0	Stepping Close Loop DSP1(X25/X27) Communication Error	The verification of the received order at stepping board is failed	Check the connection of SPI communication cable

E		6	8	1	Stepping Close Loop DSP1 1 st Route (X27) Over-Current	Large current is detected by hardware	At first, please check motor. Then check the resistance and sensor value. If the motor is ok, user should check the hardware on stepping board
E		6	8	2	Stepping Close Loop DSP11st Route (X27) Position Error	The detected encoder response position is not same to the position set tin order	Change the stepping motor to open loop mode and run it. If the motor can work normally, the motor should be ok. If the motor can not work normally, user should check the driving part on the stepping board and the motor itself. After the above works, user should check the encoder. Make sure the connection and the condition of the encoder cable is ok. And make sure the signal response part on the stepping board and the encoder itself is ok.
E		6	8	3	Stepping Close Loop DSP11st Route (X27)Over- speed	The system will give this warning when it detects the abnormal motor speed via the encoder response signal	The checking method is same to that in Position Error
E		6	8	5	Stepping Close Loop DSP12nd Route (X25) Over-Current	Large current is detected by hardware	At first, please check motor. Then check the resistance and sensor value. If the motor is ok, user should check the hardware on stepping board
E		6	8	6	Stepping Close Loop DSP12nd Route (X25) Position Error	The detected encoder response position is not same to the position set tin order	Change the stepping motor to open loop mode and run it. If the motor can work normally, the motor should be ok. If the motor can not work normally, user should check the driving part on the stepping board and the motor itself. After the above works, user should check the encoder. Make sure the connection and the condition of the encoder cable is ok. And make sure the signal response part on the stepping board and the encoder itself is ok.
E		6	8	7	Stepping Close Loop DSP12nd Route (X25) Over- speed	The system will give this warning when it detects the abnormal motor speed via the encoder response signal	The checking method is same to that in Position Error
E		6	9	0	Stepping Close Loop DSP2(X21/X23) Communication Error	The verification of the received order at stepping board is failed	Check the connection of SPI communication cable
E		6	9	1	Stepping Close Loop DSP21st Route (X23) Over-Current	Large current is detected by hardware	At first, please check motor. Then check the resistance and sensor value. If the motor is ok, user should check the hardware on

							stepping board
E		6	9	2	Stepping Close Loop DSP21st Route (X23) Position Error	The detected encoder response position is not same to the position set tin order	Change the stepping motor to open loop mode and run it. If the motor can work normally, the motor should be ok. If the motor can not work normally, user should check the driving part on the stepping board and the motor itself. After the above works, user should check the encoder. Make sure the connection and the condition of the encoder cable is ok. And make sure the signal response part on the stepping board and the encoder itself is ok.
E		6	9	3	Stepping Close Loop DSP21st Route (X23) Over- speed	The system will give this warning when it detects the abnormal motor speed via the encoder response signal	The checking method is same to that in Position Error
E		6	9	5	Stepping Close Loop DSP22nd Route (X21)Over-current	Large current is detected by hardware	At first, please check motor. Then check the resistance and sensor value. If the motor is ok, user should check the hardware on stepping board
E		7	3	0	Encoder error	The Encoder of main-shaft Motor is no signal	Check the cable of main-shaft motor
E		7	3	1	Stepping Board Error	Stepping Board can not execution command	Check the x, y stepping-motor cable
E		7	3	3	Motor Reverse	Motor Reverse	Turn off the power and check the coupling of the main-shaft motor.
E		8	1	1	Overvoltage Error	The voltage of power is over the specified value.	Confirm the voltage of power
E		8	1	3	Low Voltage Error	The voltage of power is too low.	Confirm the voltage of power.
E		9	0	1	Motor driver abnormal	The error is detected in motor driver.	Turn off the power and repower the machine after a while.
E		9	0	3	Power Supply of Pulse Motor Error	Power supply of the pulse motor is not output	Turn off the power and repower the machine after a while.
E		9	0	4	Solenoid Power Supply Error	Power supply of the solenoid cannot output	Turn off the power and repower the machine after a while.
E		9	0	7	X Origin Search Error	X origin sensor doesn't change.	Turn off power and check the connections of CZ021 on head signal circuit board and X9 on control box.
E		9	0	8	Y Origin Search Error	Y origin sensor doesn't change.	Turn off power and check the connections of CZ022 on head signal circuit board and X9 on control box.

COMPUTER-CONTROLLED HIGH SPEED LOCKSTITCH BAR TACKING MACHINE

E		9	1	0	Presser Origin Search Error	Presser origin sensor doesn't change.	Turn off power and check the connections of CZ025 on head signal circuit board and X9 on control box.
E		9	1	1	Y Direction Motor Busy	Y motor doesn't make action according to order	Check the stepping motor in Y direction.
E		9	1	2	X Direction Motor Busy	X motor doesn't make action according to order	Check the stepping motor in X direction.
E		9	1	3	Thread-catching Origin Search Error	Thread-catching origin sensor doesn't change.	Turn off power and check the connections of CZ026 on head signal circuit board and X9 on control box.
E		9	1	4	Transmission Error	Time lag exist between cloth-feeding motor and main-shaft motor	Turn off the power and repower the machine after a while.
E		9	1	6	Communication Error between Main-board and Stepping Board	Communication between Main-board and Stepping Board is down.	Turn off the power and repower the machine after a while.
E		9	9	9	Abnormal status	More than one part of machine has problem.	Make sure no sensor is plugged reversely.
No Display					Plug Take-off	The voltage of power doesn't meet standard. The plug is take-off.	Turn off power and check the connections of power plug and X7 plug on control box.

IV. Troubles and corrective measures (sewing conditions)

Trouble	Cause	Corrective measures
1.The needle thread slips off at the start of bar-tacking	<ul style="list-style-type: none"> ① Stitches are slipped at the start ② The needle thread remaining on the needle after thread trimming is too short. ③ The bobbin thread is too short. ④ Needle thread tension at 1st stitch is too high. ⑤ Thread clamp is unstable(material is apt to be expanded. Thread is hard to slide, thread is thick, etc.) ⑥ Pitch at 1st stitch is too small. 	<ul style="list-style-type: none"> ○ Adjust the clearance between the needle and the shuttle to 0.05 to 0.1mm. ○ Set soft-start sewing at the start of bar tacking. ○ Correct the thread tension release timing of the thread tension controller No.2. ○ Increase the tension of the thread take-up spring, or decrease the tension of the thread tension controller No.1. ○ Decrease the tension of the bobbin thread. ○ Increase the clearance between the needle hole guide and the counter knife. ○ Decrease the tension at 1st stitch. ○ Decrease the number of rotation at 1st stitch at the sewing start.(Extent of 600to 1000rpm) ○ Increase the number of stitches of thread clamp to 3to 4stitches. ○ Make the pitch at 1st stitch longer. ○ Decrease the needle thread tension at 1st stitch.
2.Thread often breaks or synthetic fiber thread splits finely.	<ul style="list-style-type: none"> ①The shuttle or the driver has scratches. ②The needle hole guide has scratches. ③The needle strikes the work clamp foot. ④Fibrous dust is in the groove of the shuttle race. ⑤The needle thread tension is too high. ⑥The synthetic fiber thread take-up spring is too high. ⑦The synthetic fiber thread melts due to heat generated on the needle. 	<ul style="list-style-type: none"> ○Take it out and remove the scratches using a fine whetstone or buff. ○Buff or replace it. ○Correct the position of the work clamp foot. ○Take out the shuttle and remove the fibrous dust from the shuttle race. ○Reduce the needle thread tension. ○Reduce the tension. ○Use silicone oil .
3.The needle often breaks.	<ul style="list-style-type: none"> ①The needle is bent. ②The needle hits the work clamp foot. ③The needle is too thin for the material. ④the driver excessively bends the needle. 	<ul style="list-style-type: none"> ○Replace the bent needle. ○Correct the position of the work clamp foot. ○Replace it with a thicker needle according to the material. ○Correctly position the needle according to the material. ○Widen the distance between the needle and the

	⑤ Needle thread is stepped on by the work clamp foot at the start of sewing (Needle bend)	wiper.(23 to 25mm)
4. Threads are not trimmed.	① The counter knife is dull. ② The difference in level between the needle hole guide and the counter knife is not enough. ③ The moving knife has been improperly positioned. ④ The last stitch is skipped. ⑤ Bobbin thread tension is too low.	○ Replace the counter knife. ○ Increase the bend of the counter knife. ○ Correct the position of the moving knife. ○ Correct the timing between the needle and the shuttle. ○ Increase the bobbin thread tension.
5. Stitch skipping often occurs.	① The motions of the needle and shuttle are not properly synchronized. ② The clearance between the needle and shuttle is too large. ③ The needle is bent. ④ The driver excessively bends the needle.	○ Correct the positions of the needle and shuttle. ○ Correct the positions of the needle and shuttle. ○ Replace the bent needle. ○ Correctly position the driver.
6. The needle thread comes out on the wrong side of the material	① the needle thread tension is not high enough. ② The tension release mechanism fails to work properly. ③ The needle thread after thread trimming is too long. ④ Number of stitches is too few. ⑤ When sewing length is short (End of needle thread protrudes on the wrong side of sewing product.) ⑥ Number of stitches is too few.	○ Increase the needle thread tension. ○ Check whether or not the tension disc No.2 is released during bar-tracking. ○ Increase the tension of the thread tension controller No.1. ○ Correct the position of the moving knife. ○ Turn OFF the thread clamp. ○ Turn OFF the thread clamp. ○ Use the lower plate, the hole of which is larger than the presser.

Trouble	Cause	Corrective measures
7.Threads break at time of thread trimming	①The moving knife has been improperly position.	○Correct the position of the moving knife.
8.The thread clamp is entangled with needle thread	①The needle thread at the sewing start is too long.	○Tighten thread tension controller No.1 and make the length of needle thread 33 to 36mm.
9.Uneven length of the needle thread	①The tension of thread take-up spring is too low.	○Increase the tension of the thread take-up spring.
10.The length of needle thread does not become short	①The tension of thread tension controller No.1 is too low. ②The tension of thread take-up spring is too high. ③The tension of thread take-up spring is too low and motion is unstable.	○Increase the tension of thread tension controller No.1. ○Decrease the tension of thread take-up spring. ○Increase the tension of thread take-up spring and lengthen the stroke as well.
11.The knotting section of bobbin thread at 2nd stitch at the sewing start appears on the right side.	①Idling of bobbin is large. ②The bobbin thread tension is too low. ③The needle thread tension at 1st stitch is high.	○Adjust the position of the moving knife. ○Increase the bobbin thread tension. ○Decrease the needle thread tension at 1st stitch. ○Turn OFF the thread clamp.

V. System diagram

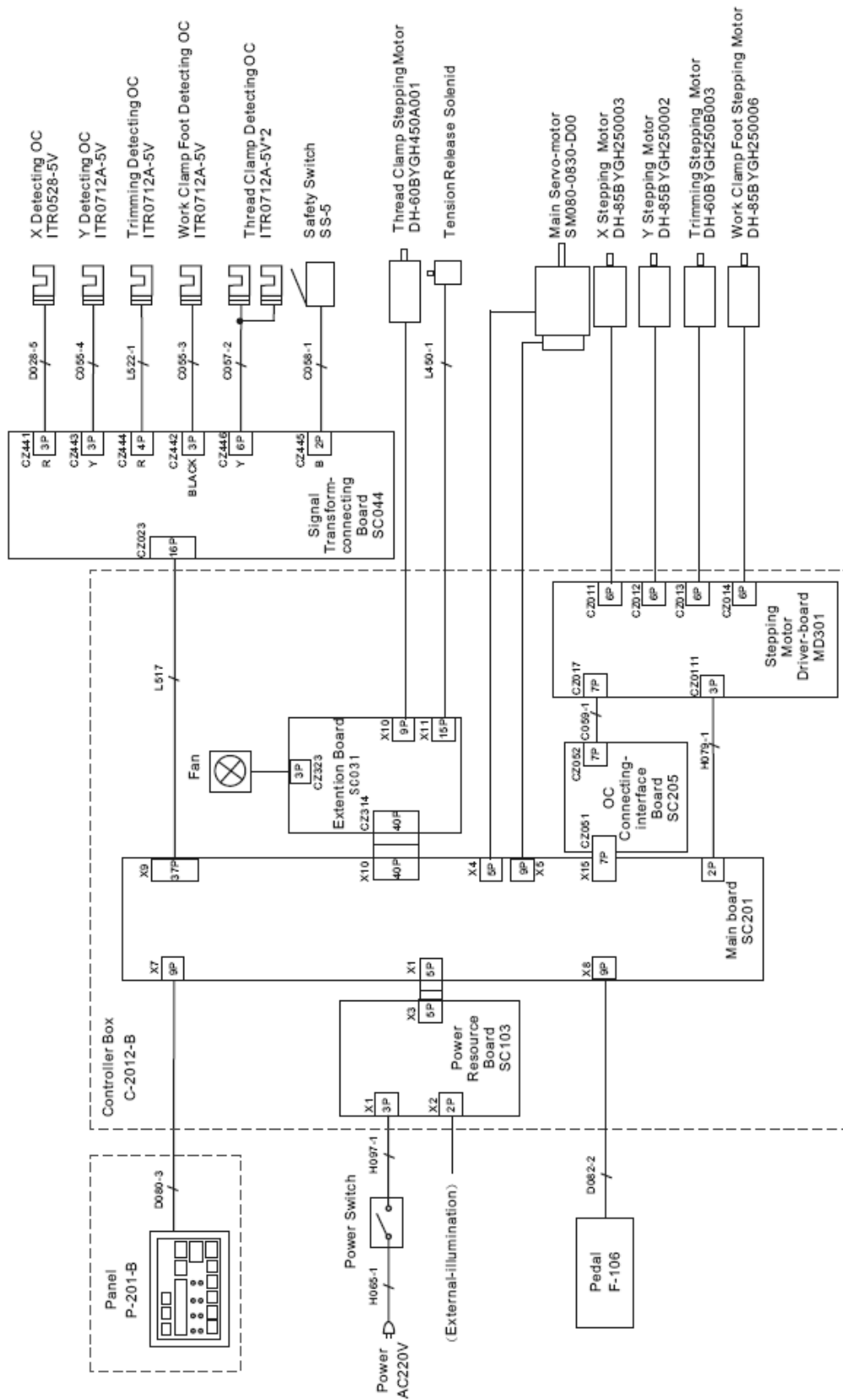

VI. DRAWING OF THE TABLE

